

THE RESPONSE OF ORGANIC TOMATOES TO THE DIFFERENT IRRIGATION  
METHODS AND FERTILIZER SUPPLY



ADEIFE VICTORIA AJADI

MASTER OF SCIENCE IN ORGANIC AGRICULTURE MANAGEMENT  
MAEJO UNIVERSITY

2023

THE RESPONSE OF ORGANIC TOMATOES TO THE DIFFERENT IRRIGATION  
METHODS AND FERTILIZER SUPPLY



ADEIFE VICTORIA AJADI

A THESIS SUBMITTED IN PARTIAL FULFILLMENT  
OF THE REQUIREMENTS FOR THE DEGREE OF MASTER OF SCIENCE  
IN ORGANIC AGRICULTURE MANAGEMENT  
ACADEMIC ADMINISTRATION AND DEVELOPMENT MAEJO UNIVERSITY  
2023

Copyright of Maejo University

THE RESPONSE OF ORGANIC TOMATOES TO THE  
DIFFERENT IRRIGATION METHODS AND FERTILIZER SUPPLY

ADEIFE VICTORIA AJADI

THIS THESIS HAS BEEN APPROVED IN PARTIAL FULFILLMENT  
OF THE REQUIREMENTS FOR THE DEGREE OF MASTER OF SCIENCE  
IN ORGANIC AGRICULTURE MANAGEMENT

APPROVED BY

Advisory Committee

Chair .....

(Dr. Wolfram Spreer)

...../...../.....

Committee .....

(Dr. Chomchuan Boonrahong)

...../...../.....

Committee .....

(Associate Professor Dr. Unchalee

Sanguanpong)

...../...../.....

Program Chair, Master of Science .....

in Organic Agriculture Management (Associate Professor Dr. Rapeephun

Dangtungee)

...../...../.....

CERTIFIED BY THE OFFICE OF

ACADEMIC ADMINISTRATION

.....

(Associate Professor Dr. Yanin

Opatpatanakit)

AND DEVELOPMENT

Vice President

...../...../.....

ชื่อเรื่อง	การตอบสนองของมะเขือเทศอินทรีย์ต่อวิธีการชลประทานและปุ๋ยที่แตกต่างกัน
ชื่อผู้เขียน	Miss Adeife Victoria Ajadi
ชื่อปริญญา	วิทยาศาสตรมหาบัณฑิต สาขาวิชาการจัดการเกษตรอินทรีย์
อาจารย์ที่ปรึกษาหลัก	Dr. Wolfram Spreer

### บทคัดย่อ

การจัดระบบน้ำและปุ๋ยถือได้ว่าเป็นสองปัจจัยหลักที่สำคัญต่อการเจริญเติบโตของมะเขือเทศ ผลการศึกษาจากการทดลองการใช้ระบบน้ำและชนิดปุ๋ยในช่วงเวลาที่เหมาะสมส่งผลให้ได้รับผลผลิตที่ดี ในการศึกษาครั้งนี้ ประเภทปุ๋ยที่ใช้ในการทดลองได้แก่ ปุ๋ยมูลวัวและปุ๋ยมูลไก่ ระบบน้ำที่ใช้ในการทดลองได้แก่ ระบบน้ำหยด (Drip irrigation) และระบบอีโคทิวป์ (Eco-Tube) สายพันธุ์มะเขือเทศอินทรีย์ 3 สายพันธุ์ ได้แก่ พันธุ์อีเปอ พันธุ์สีดา และพันธุ์ท้อ นอกจากนี้ยังใช้มะเขือเทศลูกผสมสายพันธุ์เพชรชมพู ในการทดลองแบบควบคุม ผู้วิจัยได้ทดลองปลูกมะเขือเทศในช่วงฤดูร้อนและฤดูฝน โดยการทดลองในช่วงฤดูฝนผู้วิจัยได้ทดลองในโรงเรือนพลาสติกโปร่งแสง (Polytunnels) จากผลการทดลองโดยการเปรียบเทียบระบบน้ำทั้ง 2 รูปแบบพบว่า ระบบการใช้น้ำแบบอีโคทิวป์มีประสิทธิภาพสูงกว่าเมื่อเปรียบเทียบกับระบบน้ำหยดในการทดลองช่วงฤดูร้อน ในขณะที่ในช่วงฤดูฝนระบบน้ำหยดมีประสิทธิภาพสูงกว่าระบบน้ำอีโคทิวป์ ผลการทดลองด้านผลผลิตในช่วงฤดูร้อนรวมกับการให้น้ำทั้งสองรูปแบบพบว่าไม่มีความแตกต่างกัน อย่างไรก็ตาม ผลผลิตที่สูงกว่ามีผลมาจากการให้น้ำโดยระบบน้ำหยดเมื่อเปรียบเทียบกับระบบน้ำแบบอีโคทิวป์ในช่วงฤดูฝน นอกจากนี้ความแตกต่างของสายพันธุ์แสดงให้เห็นการตอบสนองที่ดีต่อปุ๋ยมูลไก่เมื่อเปรียบเทียบกับปุ๋ยมูลวัว และเมื่อเปรียบเทียบกันระหว่าง 3 สายพันธุ์ พบว่ามะเขือเทศสายพันธุ์ “อีเปอ” ให้ผลผลิตสูงกว่าสายพันธุ์อื่นในการทดสอบครั้งนี้ในมะเขือเทศทั้ง 3 สายพันธุ์พบว่า สายพันธุ์อีเปอร่วมกับการใช้ปุ๋ยมูลไก่และให้น้ำระบบอีโคทิวป์ในช่วงฤดูร้อน และมะเขือเทศพันธุ์ลูกผสมโดยการปลูกในโรงเรือนพลาสติกโปร่งใส ร่วมกับการให้น้ำระบบน้ำหยดในช่วงฤดูฝน การทดลองทั้ง 2 รูปแบบได้ผลผลิตที่สูงที่สุด สำหรับเกษตรกรผู้ผลิตมะเขือเทศที่ต้องการผลผลิตสูง สิ่งจำเป็นที่จะต้องพิจารณาได้แก่สายพันธุ์ที่เหมาะสม

คำสำคัญ : มะเขือเทศ, ระบบน้ำหยด, อีโคทิวป์, โรงเรือนพลาสติก, ปุ๋ยอินทรีย์

<b>Title</b>	THE RESPONSE OF ORGANIC TOMATOES TO THE DIFFERENT IRRIGATION METHODS AND FERTILIZER SUPPLY
<b>Author</b>	Miss Adeife Victoria Ajadi
<b>Degree</b>	Master of Science in Organic Agriculture Management
<b>Advisory Committee Chairperson</b>	Dr. Wolfram Spreer

### ABSTRACT

Water and fertilizer, are two important factors affecting tomato vegetative growth and reproductivity. Using the right irrigation and fertilization measures, at the right time can boost fruit yield. In this research, the influence of fertilizer (cow and poultry starter fertilizer) supply and irrigation (drip irrigation and eco tubes irrigation) systems on the growth and yield of three organic varieties (Eber, Sida, and Tor) and one Hybrid Variety (phetchompous Tok. Piyawan) as control, was evaluated. The research was carried out during the dry and rainy seasons, with the introduction of polytunnels in the rainy season. The result showed high water use efficiency (WUE) with the use of eco tubes compared to drip irrigation in the dry season, and high water use efficiency in drip irrigation as compared to eco tube irrigation in the rainy season. In terms of the yields obtained, there were no notable differences between the two methods of irrigation in the dry season. However, drip irrigation obtained a higher yield than eco-tube irrigation in the rainy season. The different varieties performed better with the application of poultry starter fertilizer than with the application of cow starter fertilizer. Among the 3 organic varieties used, eber variety had a better performance in terms of yield. In this experiment, the treatment combination of eber variety, poultry starter fertilizer, and eco tube irrigation during the dry season and hybrid variety, polytunnels, and drip irrigation during the rainy season produced the highest yield. For farmers to achieve high yields, they must use good genetic materials.

Keywords : Tomato, drip irrigation, eco tubes, polytunnels, organic fertilizer



## ACKNOWLEDGEMENTS

My heartfelt gratitude goes to my Lord Jesus Christ for keeping me alive and providing me with the spiritual guidance, grace, and strength needed to finish this program.

I want to express my deep gratitude to Dr. Wolfram Spreer, my supervisor, for his fatherly support, patience, and guidance throughout my research project. A special thank you to Mrs. Aae Wolfram for her kind words and assistance throughout this project. In addition, I would like to thank the members of my committee, Dr. Chomchuan Boonrahong, Assoc. Prof. Dr. Unchalee Sanguanpong, and Dr. Sanjay Rangappa, for their suggestions that helped make this work possible

I especially want to thank the international college and Maejo farm for allowing me to conduct my research on the Maejo international farm and for providing me with a scholarship. Mrs. Julijanna Sirikhampa, thank you for guiding and assisting me throughout this program. A special thanks go to the entire staff of the international college for their assistance and support throughout my program.

And most importantly, I want to thank my amazing parents, Barr. and Mrs. Ajadi, who provided me with the original inspiration, support, and trust that enabled me the confidence to conquer all the obstacles and difficulties while completing this research paper.

Last but not least, I would want to thank my incredible uncle, Dr. Adu Toyin for his fatherly counsel, support, and, for believing in me.

Adeife Victoria Ajadi



## TABLE OF CONTENTS

	<b>Page</b>
ABSTRACT (THAI).....	C
ABSTRACT (ENGLISH).....	D
ACKNOWLEDGEMENTS .....	F
TABLE OF CONTENTS.....	G
List of Tables.....	K
List of Figure.....	L
CHAPTER 1.....	1
INTRODUCTION.....	1
1.1 Background study.....	1
1.2 Aim.....	3
1.3 The Objective of the research.....	3
1.4 The hypothesis of the study.....	3
1.5 Scope of study.....	3
CHAPTER 2.....	5
LITERATURE REVIEW .....	5
2.1 Agriculture.....	5
2.2 Organic agriculture in Thailand.....	6
2.3 Organic and conventional agriculture.....	7
2.4 Tomato production in Thailand.....	10
2.5 Varieties of tomatoes .....	12
2.6 Nutritional values of tomato .....	13



2.7 Fertilizers.....	13
2.7.1 Mineral fertilizer .....	13
2.7.2 Organic fertilizer .....	15
2.8 Irrigation.....	16
2.8.1 Drip Irrigation.....	16
2.8.2 Eco tube irrigation (porous pipe).....	17
2.9 Factors affecting the quality of tomato fruit.....	18
2.9.1 Temperature .....	18
2.9.2 Water .....	19
2.9.3 Soil.....	19
2.10 Polytunnels .....	20
CHAPTER 3.....	21
MATERIAL & METHODS .....	21
3.1 Study area.....	21
3.2 Land preparation.....	21
3.3 Varieties.....	22
3.4 Varieties and properties according to suppliers.....	23
3.4.1 Eber.....	23
3.4.2 Sida .....	23
3.4.3 Tor.....	23
3.4.4 Hybrid (phetchompous Tok. Piyawan).....	24
3.5 Seedling treatments and planting .....	24
3.6 Irrigation management .....	27
3.6.1 Drip irrigation.....	27

3.6.2 Eco tubes.....	27
3.7 Starter fertilizer .....	29
3.8 Location: Experimental design and layout .....	30
3.8.1. Dry season experiment.....	30
3.8.2 Rainy season experiment .....	33
3.9 Irrigation.....	35
3.10 Cultural practices .....	39
3.11 Pest and disease management .....	40
3.12 Plant height measurement .....	43
3.13 Harvesting .....	44
3.14 Statistical analysis .....	45
3.13 Crop water requirement and irrigation scheduling .....	51
CHAPTER 4.....	55
RESULTS AND DISCUSSION.....	55
4.1 Yield performance according to treatment in the dry season .....	55
4.2 Crop yield performances According to Varieties in the dry season.....	58
4.3 Yield performances according to treatment in the Rainy Season .....	59
4.4 Crop yield performances According to Varieties in the Rainy season.....	61
4.5 Irrigation analysis for dry season .....	62
4.6 Plant Height According to Varieties .....	65
4.7 Plant growth during the dry season and rainy season .....	67
4.8 Plant Height According to the Irrigation system.....	69
4.9 Plant response to Irrigation .....	70
4.10 Plant Height According to Fertilizer.....	72

CHAPTER 5..... 73

CONCLUSION AND RECOMMENDATION ..... 73

REFERENCES ..... 78

CURRICULUM VITAE..... 90



## List of Tables

	<b>Page</b>
Table 1 Fundamental differences between conventional and organic agriculture. ....	8
Table 2 Temperature Range.....	18
Table 3 Chemical properties of soil from study area. ....	22
Table 4 The different Varieties and their uses. ....	24
Table 5 Chemical composition of organic fertilizer used. ....	29
Table 6 Chemical composition of fish fertilizer analysis.....	30
Table 7 Treatment details for the dry season of planting.....	31
Table 8 Treatment details for the rainy season of planting.....	34
Table 9 Different factors used for the experiment.....	35
Table 10 Irrigation analysis for Eber and Sida varieties in the dry season.....	63
Table 11 Irrigation analysis for Hybrid and Tor varieties in the dry Season.....	64
Table 12 Eber and Sida irrigation analysis in the rainy season. ....	64
Table 13 Hybrid irrigation analysis in the rainy season.....	64
Table 14 Maximum and minimum temperature, the relative air humidity, amount of rainfall, and reference crop evapotranspiration in both rainy and dry seasons. ....	65

## List of Figure

	<b>Page</b>
Figure 1 Organic vs. conventional agriculture.....	8
Figure 2 The world organic producers in 2020.....	9
Figure 3 Different provinces in Thailand producing tomatoes.....	11
Figure 4 Tomato production by region and top 10 tomato-producing countries. ....	12
Figure 5 Location of Maejo university organic farm.....	21
Figure 6 Land preparation.....	22
Figure 7 Comparing seedlings in the tray 2 weeks after planting in the nursery. ....	25
Figure 8 Seedlings in the greenhouse being manually irrigated.....	26
Figure 9 Hardening off of seedling before transplanting.....	26
Figure 10 Drip irrigation.....	27
Figure 11 Eco tube irrigation.....	27
Figure 12 Polyunnel installed on the field.....	28
Figure 13 Polyunnel on the field.....	28
Figure 14 Drip irrigation system irrigation on the field.....	32
Figure 15 Eco tube irrigation system on the field.....	33
Figure 16 Eco tube irrigation under the use of polytunnels.....	34
Figure 17 Drip irrigation under the use of polytunnels.....	35
Figure 18 Dripline emitting water to the tomato plant.....	36
Figure 19 Overview of the irrigation systems.....	36
Figure 20 The tanks supplying water to the field.....	37
Figure 21 The irrigation setup.....	38

Figure 22 Disc filter and mesh filter.....	39
Figure 23 Staking done on the field.....	40
Figure 24 Preparing the Trichoderma before application.....	41
Figure 25 Applying Trichoderma to the field.....	42
Figure 26 Spraying of the field using the knapsack sprayer.....	43
Figure 27 Plant measurement at an early stage of growth. ....	44
Figure 28 Tomato plant at flowering stage. ....	45
Figure 29 Complete flowering and early stage of fruiting. ....	46
Figure 30 Eber variety under drip irrigation with no polytunnel.....	46
Figure 31 Tomato plant under eco tube irrigation. ....	47
Figure 32 Hybrid variety with drip irrigation and polytunnels. ....	48
Figure 33 Sida variety polytunnel and eco tube irrigation.....	49
Figure 34 Fruit development in tomato plant. ....	50
Figure 35 Development of fruits.....	50
Figure 36 Marketable Eber varieties and marketable Hybrid and Sida.....	51
Figure 37 Biomass in a solar dryer. ....	51
Figure 38 FAO climate data analysis for irrigation planning.....	52
Figure 39 FAO climate data analysis for irrigation planning.....	53
Figure 40 Crop water requirement (CWR) for the experimental period.....	54
Figure 41 Crop water requirement (CWR) for the experimental period.....	54
Figure 42 Yield according to treatment combination in the dry season. ....	56
Figure 43 Yield according to starter fertilizer in the dry season. ....	57
Figure 44 Yield according to the different irrigation systems in the dry season. ....	57
Figure 45 Yield according to the different varieties used in the dry season.....	58

Figure 46 Yield according to treatment combination in the rainy season. ....	60
Figure 47 Yield according to the two irrigation systems in the rainy season. ....	60
Figure 48 Yield according to the use of polytunnels and no polytunnels in the rainy season. ....	61
Figure 49 Yield according to different varieties used in the rainy season. ....	62
Figure 50 Plant height according to varieties in the dry season. ....	66
Figure 51 Plant height according to varieties in the rainy season. ....	67
Figure 52 Plant growth in the dry season. ....	68
Figure 53 Plant growth in the rainy season. ....	68
Figure 54 Plant height according to irrigation for the dry season. ....	69
Figure 55 plant height according to irrigation for the rainy season. ....	70
Figure 56 The response of plant height to irrigation in the dry season. ....	71
Figure 57 The response of plant height in the rainy season. ....	71
Figure 58 Plant height according to fertilizer. ....	72



## CHAPTER 1

### INTRODUCTION

#### 1.1 Background study

Tomato (*Solanum Lycopersicum* L.), is the second-largest fruit or vegetable crop after potatoes. Asia produces 61.1% of the world's tomatoes, with Europe, America, and Africa contributing 13.5%, 13.4%, and 11.8% to the total yield (Quinet et al., 2019). Tomato is a member of the *Solanaceae* family, which also includes several other economically significant crops like potato, pepper, and eggplant, representing one of the most valuable plant families for vegetable and fruit crops. Tomatoes are generally propagated from seeds in a nursery and transplanted later. To maintain optimum production, intensive agronomic practices including watering, weeding, pruning, training, pest, and disease control are used (Gatahi, 2020). The plant grows to a height of 1–3 meters and has a weak stem that often sprawls over the ground and vines over adjacent plants, causing decumbence if left untrained. It is a perennial in its native habitat; however, it is commonly planted as an annual in temperate areas. An average tomato weighs around 100 grams. Tomato as a crop is ideally suited for tropical and sub-tropical climates, where it grows well in temperatures ranging from 15 to 30 ° C. With moderate rainfall of about 1000 millimeters (Nicola et al., 2009). Numerous issues, such as a lack of water resources, soil salinization, and other abiotic pressures, pose challenges to tomato cultivation throughout the world (Zhou et al., 2019). Growing tomatoes requires a lot of care and time since few vegetables are prone to more problems than tomatoes. The best way of growing tomatoes is to choose site-adapted varieties, start the plants off right, and control problems before they happen. The use of agrochemicals, especially in pest and disease management, is the largest challenge in tomato production. The indiscriminate use of pesticides has resulted in a large build-up of chemical residues, posing a threat to the production of safe tomatoes in the world (Karungi et al., 2011). As a result, several initiatives have been put in place to guarantee that the value chain is maintained sustainably. Production in protected

environments is one of these projects, which aims to provide ideal production circumstances. In addition, regulatory standards such as global good agricultural practices (GGAP) and good manufacturing practices (GMP) are being developed to assure responsible and ethical production, traceability, chemical use, and worker welfare. Another major criterion is the organic standard, which curbs the use of synthetic pesticides and reduces chemical residues in the fruits, making them safe to eat and containing few contaminants. Organic products are also more premium and have a smaller market (Gatahi, 2020). Tomatoes cultivated organically have recently gained popularity around the world. While most tomatoes are grown using a variety of pesticides, organic tomato production will provide stakeholders with the assurance that no dangerous synthetic chemicals have been applied (Ugonna et al., 2015). Chemicals have an impact on the farmer, the consumer, and the environment. Tomatoes contain many health-promoting compounds and are easily integrated as a nutritious part of a balanced diet (Martí et al., 2016). In addition to consuming fresh fruits, consumers use tomatoes in processed products such as soups, juices, and sauces. Over the last decade, consumers have become more aware of foods as a source of health benefits and their roles in the prevention of several chronic diseases (Pem and Jeewon, 2015). Although a wealth of functional foodstuffs has been created to fulfill these requirements, it is important to note that the consumption of conventional foods such as fruits and vegetables is more effective for this purpose. The nutritional importance of tomatoes is largely explained by their various health-promoting compounds, including vitamins, carotenoids, and phenolic compounds. Tomatoes are rich in carotenoids, representing the main source of lycopene in the human diet (Viuda-Martos et al., 2014). Carotenoids and polyphenolic compounds contribute to the nutritional value of tomatoes and improve their functional attributes and sensory qualities, including taste, aroma, and texture.

## 1.2 Aim

This research seeks to determine the responses of organic tomatoes to different irrigation methods and fertilizers.

## 1.3 The Objective of the research

1. To see the response of different varieties to irrigation systems and starter fertilizers.
2. To see the influence of different irrigation systems on yield.
3. To evaluate the performance of different varieties between the two seasons of planting.
4. To analyze the cropping potential of the season and the implication on organic farming.

## 1.4 The hypothesis of the study

1. There is a significant difference between crop performance in the use of drip irrigation and eco tube irrigation.
2. The water use efficiency in drip irrigation is significantly different from the water use efficiency in eco tube irrigation.
3. There is no significant difference between the use of poultry starter fertilizer and cow starter fertilizer.
4. Organic farmers can produce tomato varieties in both dry and rainy seasons and achieve high yields.

## 1.5 Scope of study

The study was carried out on Maejo University organic farm located at latitude 18°54'54.0"N longitude 99°03'25.7"E. The experiment was repeated twice during dry season and rainy season, respectively. During the rainy season, polytunnels were used. Four varieties, comprising three organic Varieties (Eber, Tor, and Sida) and one hybrid (phetchompous Tok. Piyawan), variety was used for the study. The experiment had a 3-factorial design with 16 treatments for the dry season and a 3-factorial design with 12 treatments for the rainy season. The study examined; the response of different

varieties of tomatoes to irrigation systems and starter fertilizer, the influence of different irrigation systems on yield, the performances of the different varieties between the two -seasons of planting, the cropping potential of the season, and the implication on organic farming.



## CHAPTER 2

### LITERATURE REVIEW

#### 2.1 Agriculture

Agriculture is the major employer of labor in most countries, providing jobs for, both the elderly and the young, male, and female (White, 2012). Plants provide man with food, fiber, clothing, medicine, and shelter, among other things. Plant growth and yield are thus dependent on nutrient cycling and recycling between plant biomass and organic and inorganic soil reserves in all environments. Agriculture evolved because of man's desire to feed himself, his family, and his animals. Agriculture has been discovered over time to attract many inputs from art, science, and business in the production of plants and animal products for the benefit of people. In agriculture, plants are the primary producers. Primitive agriculture relied on natural resources such as soil, rainfall, and indigenous plant. Plants and organisms that decrease the productivity of beneficial plants and animals were avoided or regulated. The system's productivity was low, and it could only feed the farmers and their families. Due to population pressures and urbanization, agricultural practices improved with the use of high external inputs such as inorganic fertilizers and agrochemicals for pest and weed control, which helped to increase productivity but had severe negative consequences for the environment and humans, making the entire system unsustainable. The agricultural production system has evolved from indigenous to modern agriculture, with agriculture becoming more dynamic and refined over time (Ibeawuchi et al., 2015). Agriculture has always been important in human history. Agriculture was the main source of income before the Industrial Revolution, and it allowed the human population to expand. As a result, agricultural expansion has come to be considered a necessary condition, if not a prerequisite, for the advancement of human civilization. Even though agriculture's percentage of total GDP has been declining, agriculture remains vital following the Industrial Revolution. On the one hand, agriculture remains a critical and unique tool for reducing poverty, particularly in rural areas (Chen and Gong, 2021; Thirtle et al., 2003). In addition, has a substantial impact on

industrialization, urbanization, and the economy's long-term evolution (Ashraf and Galor, 2011).

Thailand is an agricultural country and agriculture is very competitive. Agriculture covers around 21 million hectares or 40.9% of the land area. Rice is cultivated on 49.8% of agricultural land, 21.5% for field crops, 21.2% for fruit or horticultural crops, and 7.5% for other crops grown. Agriculture is a significant industry that employs most of the country's rural population. This industry employs approximately 46.6%. Although agriculture's importance has diminished due to the expansion of other sectors (Thepent and Chamsing, 2009). In recent years, there has been some growth, although it has been quite slow. Thailand has been a successful agricultural country despite some economic downturns, and this is due to the country's abundant natural resources, which range from different crops to farming and fishing (Fan et al., 2004). Crop production is the most important agricultural sub-sector of Thailand. In 2010, it contributed around 61.8% of Thailand's gross agricultural output, followed by livestock (15.6%), fisheries (22.4%), forestry (0.02%), and others (0.18%). Rice, maize, sugarcane, cassava, and soybean are Thailand's five most important crops in terms of cultivated area and value of output, with 10.75, 1.11, 1.14, 1.03, and 0.16 million ha, respectively. Rice, maize, and sugarcane are key food and foreign exchange earners in the country. Other major crops in Thailand include rubber, maize, sugar cane, tapioca, and oil palm. (Thepent and Chamsing, 2009).

## **2.2 Organic agriculture in Thailand**

In Thailand Agriculture is the major pillar of the country. The majority of people depend on the agricultural sector for their upkeep and steady source of income. Globally Thailand is among the top 10 countries known for the export of agricultural products this is because of its good agro-climatic condition (Rugchat, 2021). Organic agriculture is not a new approach in Thailand, it has been in practice since the 1980s. In 1989, the Alternative Agriculture Network (AAN) was established as a national network by farmers and non-government organizations (NGOs) to support sustainable agriculture as well as organic agriculture and to educate grassroots NGOs and farmer leaders. In 1992, a conference about organic agriculture was done as a part of the

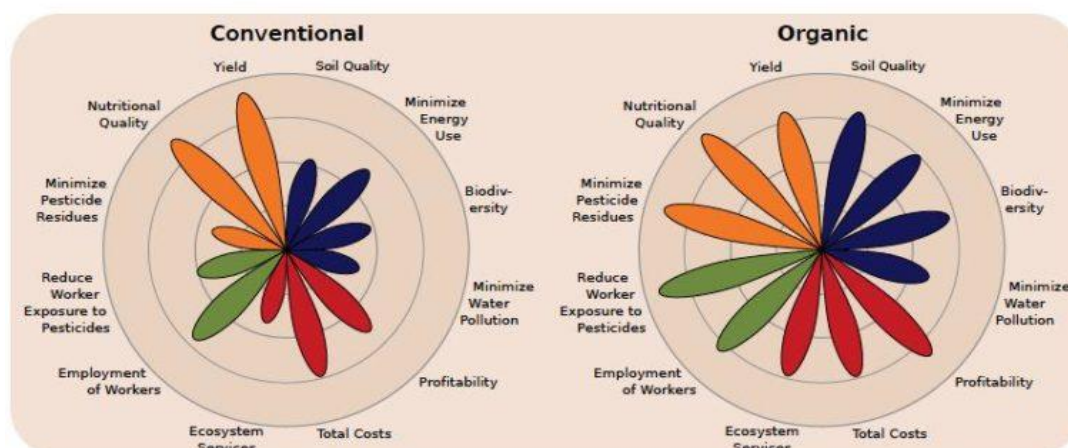


sustainable agricultural movement (Ellis et al., 2006). Organic agriculture was first introduced to Thailand by non-governmental organizations (NGOs), to reduce the cost of agricultural inputs and bring an increase in the income of farmers. It is additionally geared toward reducing the health risks farmers and consumers encounter during production and consuming chemically produced products. Organic agriculture is in general, promoted by NGOs, government agencies, farmers' groups, and consumers who are bothered about the consequences of chemicals on both environment and human health (Pattanapant and Shivakoti, 2013). According to (Thapa and Rattanasuteerakul, 2011) study, they are two kinds of organic farming in Thailand; integrated organic farming system and mono-crop organic farming system. In the integrated organic farming system, many varieties of the plant are cultivated in one-unit area of land to decrease the cost of production and get self-sufficiency by engaging in numerous agricultural farming activities. This sort of farming system also drives environmentally friendly production to support an ecological balance. The mono-crop organic farming system emphasizes the increased revenue from farming activities through production methods from farm to table. This farming system is additionally thought of to be environmentally safe.

### **2.3 Organic and conventional agriculture**

The practice of conventional agriculture had posed a threat to the earth's long-term sustainability as well as human health. Agroecosystems and human health had been harmed by the widespread use of chemo-synthetic inputs. Chemo-synthetic pesticides, for example, kill not just pests but also other organisms in the agro-ecosystem; high pesticide residues have been found to harm people in some locations; and intensive use of chemo-synthetic fertilizers has damaged the soil and polluted the water (Jahroh, 2010). Figure 1 below shows the fundamental differences between conventional and organic agriculture; organic agriculture is a viable option for achieving sustainable Agriculture.





**Figure 1** Organic vs. conventional agriculture.

Source: (Morgan and Murdoch, 2000).

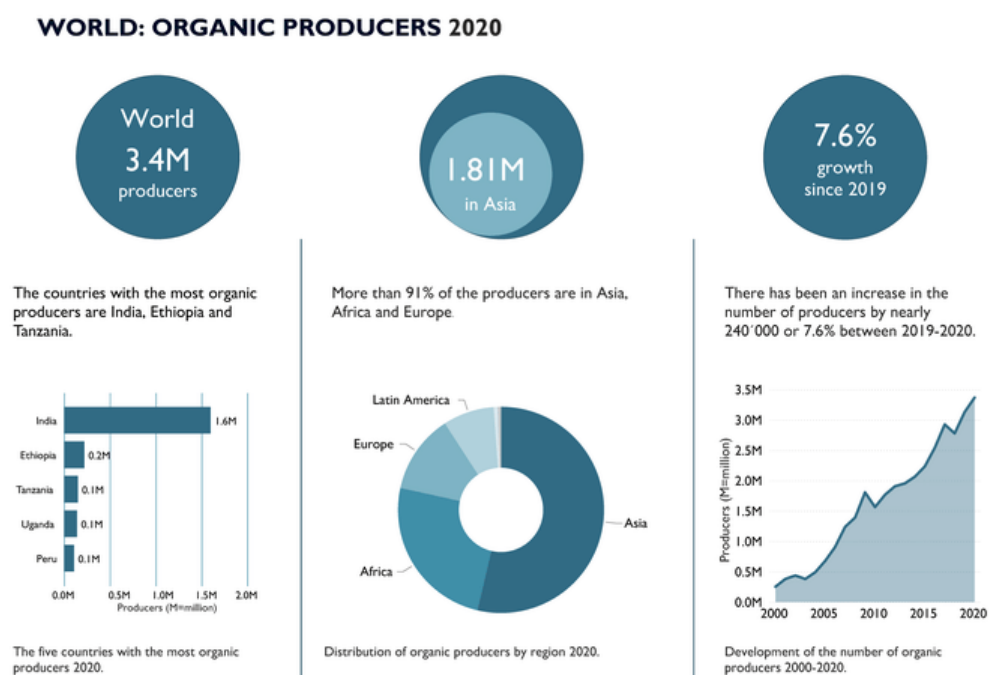
**Table 1** Fundamental differences between conventional and organic agriculture.

Source: (Niggli, 2007).

Conventional Agriculture	Organic Agriculture
Centralization	Decentralization
Dependence	Independence
Competition	Community
Domination of nature	Harmony with nature
Specialization	Diversity
Exploitation	Restraint

Organic farming's sustainability can be assessed from three perspectives: economic, social, and environmental (Jahroh, 2010). From an economic aspect perspective, organic agriculture reduces production costs by avoiding the use of external chemosynthetic inputs. Farmers will have a bigger profit margin due to the higher price of organic food. According to numerous research, in early adoption yields decrease, whereas later yields grow and then remain constant. As a result, organic farming is thought to be economically viable (Kshirsagar, 2008). Social aspect wise, Organic farming communities demonstrate community development by establishing

trust among themselves, their neighbors, and the public simply by existing. Organic farmers respect the environment and their culture, develop their human capacities through knowledge and information sharing, and speak up in their communities and local governments (Jahroh, 2010). In terms of the social aspect, organic farming's sustainability can be achieved through strong community building. Environmentally, Organic farming ensures the long-term viability of the environment. Organic agriculture's environmental benefits have been well established, including ecosystem services, biodiversity preservation, reduced resource usage, environmental protection, landscape values, and reduced energy consumption (Jahroh, 2010). Organic farming has also been shown to boost soil fertility by increasing the biomass of cereal and potato organic farms in various tests. Functional richness and variety were found to be highest for organic treatments and lowest for conventional treatments based on substrate use patterns. In addition, a study in Switzerland found that the long-term microbial characteristics of organic soils differ significantly from those of conventional and integrated soils (Niggli, 2007). Figure 2 below shows the world organic producers in 2020.



**Figure 2** The world organic producers in 2020.

Source: (Willer and Sahota, 2020).

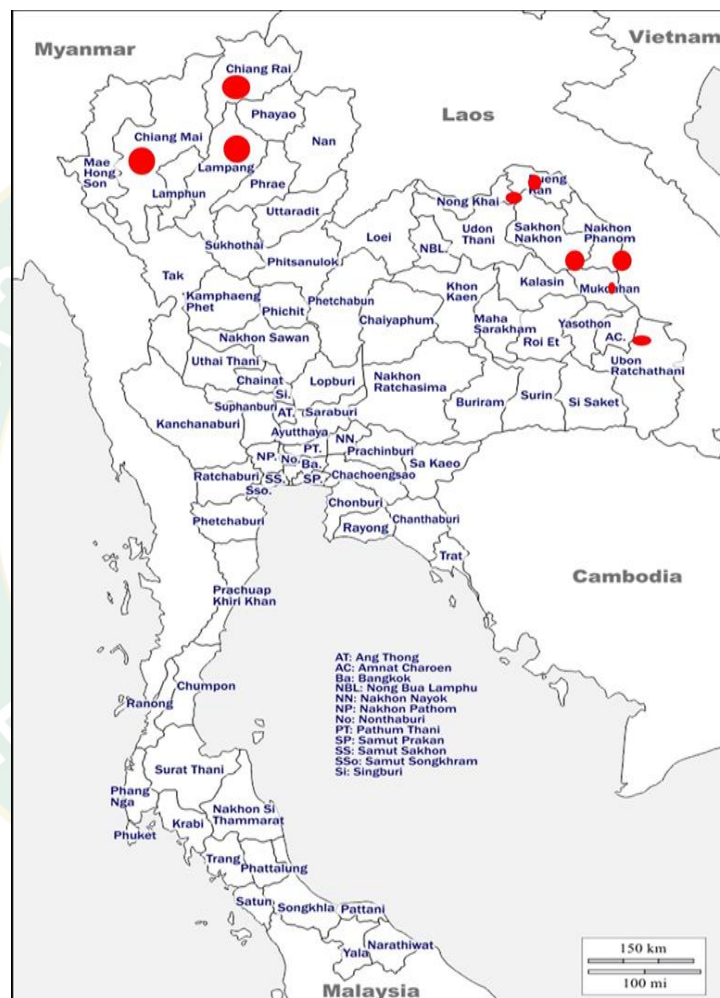
## 2.4 Tomato production in Thailand

The Food and Agriculture Organization Statistical Database reported that China is the largest tomato producer, followed by India and the United States with global production in 2013 reaching almost 163 million tons. Indonesia leads Southeast Asia in tomato production followed by the Philippines and Thailand. Areas planted with tomatoes have increased in Thailand reaching 5,339 ha in 2013, and as more plantings occur on less suitable sites, the incidence and severity of the disease have increased (Suwannarach et al., 2016). (Rugchat, 2021), states that tomato is a key vegetable fruit that is widely cultivated for commercial purposes in Thailand, throughout 2016-2017 the area and total production of tomato was around 6,028 ha and 122,593 tons respectively, and its productivity was about 21.88 tons/ha.

The main tomato-growing areas in Thailand are in the north and northeast of the country. For more than three decades, Chiang Mai province in northern Thailand has been Thailand's major tomato-producing area. According to recent data from the Economics (OAE), Chiang Mai had tomato growing areas of around 6,609 rai<sup>3</sup>, while Sakon Nakhon and Nona Khadi in northeast Thailand had 5,702.5 rai and 4,509.5 rai, respectively, between 2011 and 2016. Chiang Mai, Salon Nakhon, and Nong Khai produced an average of 22,749.83, 21,629.83, and 20,592.16 tons of tomatoes every year, respectively (Rugchat, 2021). The majority of farmers frequently use the crop-producing lands around the Mekong River. Hybrid and local tomato cultivars are grown using crop rotation. Tomatoes are first grown when the water levels in the Mekong River are low. The nutrient-rich soil along the riverside increases the quality of the crops even more. Tomato seedlings are planted from October to November during the dry season and harvested from January to March during the wet season. During the wet season, from May to September, most farmers plant rice. Farmers who do not have access to a greenhouse can create an open-access system with bamboo trellises and rope structures.

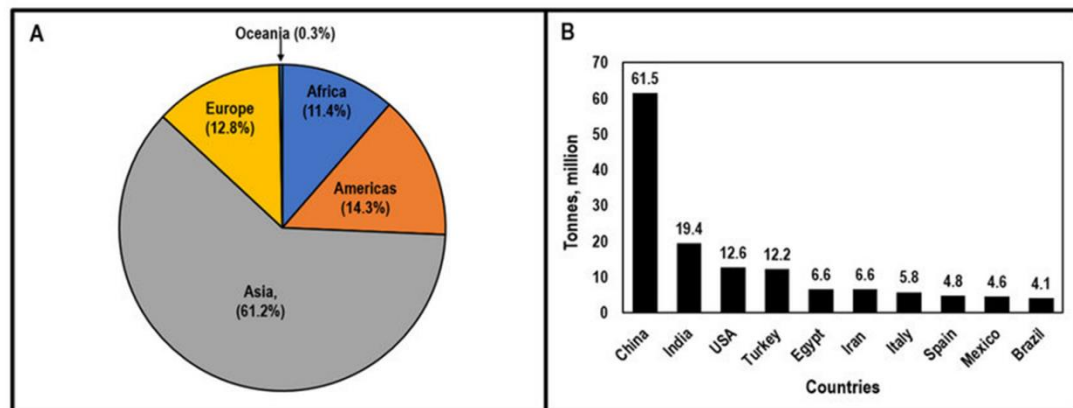
Thai tomato growers lack the technical efficiency and plant management tools that would help them increase their yield. Seed companies have been helpful in the introduction of improved processing of tomato varieties. Competition among seed companies has resulted in the production of high-quality seeds. The provinces of Nong

Khai, Bueng Kan, Nakhon Panom, Mukdahan, and Amnat Charoen have the highest tomato yields in the country because of these conditions. THB (Thai baht) 40,000 per rai is about equivalent to EUR 6,660 (or USD 7,980) per hectare when tomatoes are grown in these areas (Eaton et al., 2008). Thailand's tomato-producing provinces are shown in figure 3 below.



**Figure 3** Different provinces in Thailand producing tomatoes.

Source: (Rosset et al., 2021).



**Figure 4** Tomato production by region and top 10 tomato-producing countries.

Source : (Acharya et al., 2020).

## 2.5 Varieties of tomatoes

Approximately 7,500 tomato varieties are grown for different reasons. Tomatoes are divided into two categories: determinate and indeterminate. Determinate or bush types produce crops all at once and stop growth at a specific height. Commercial growers that want to harvest an entire field at once like them. Indeterminate varieties generate vines that never top off under ideal growing environments and continue to bear fruit until the first frost. Commercial fresh market producers and home growers who desire ripe fruit throughout the growing season are favored them (Balaj et al., 2017). Tomato varieties are typically grown based on their intended use or destination. They can either be consumed fresh by consumers or utilized in the processing of tomato products by manufacturers. Fresh market tomatoes and processed tomatoes have different production methods. Today available varieties are resistant to many diseases that are caused by pathogenic fungi, bacteria, viruses, and nematodes as well as abiotic factors (Nicola et al., 2009). To meet commercial requirements of both fresh market and processing tomato-type, fruit varieties are chosen based on fruit size, color, texture, and acidity. Tomatoes for the fresh market are hand-picked and often red, though they can vary in color, shape, and size; tomatoes for the processing business are typically machine-harvested and should have an intense red color and high solids content suited for making a paste, ketchup, or sauce (Ha, 2015). Tomato breeding has recently, gained popularity as a means of producing fruit with a long shelf life,



resistance to bruising, and high lycopene content. Commercial tomato cultivation in the tropics currently requires tomato varieties that can tolerate high temperatures, diseases, and insect pressure. When the climate for cultivation is appropriate, most tomato varieties are adapted to the dry season (Ha, 2015).

Wet season production, on the other hand, requires a mix of a suitable variety and particular management measures, such as the use of a fruit-set growth regulator, grafting, or the use of shelters to handle excessive rainfall (Gatahi, 2020).

## 2.6 Nutritional values of tomato

Tomato is presently a vital food part grown globally. Tomatoes are after all the second largest vegetable in terms of production and consumption (Dorais et al., 2008). Tomatoes are said to be a supplier of vitamins and pro-vitamins (vitamin C, pro-vitamin A,  $\beta$  carotene, folate), minerals such as potassium, and secondary metabolites such as lycopene, flavonoids, phytosterols and polyphenols (Beecher, 1998; Luthria et al., 2006). Thus, 100 g of tomato gives over 46%, 8%, and 3.4% of the daily necessities of vitamin A (900 UE), ascorbic acid (82.5 mg), and potassium (3500 mg), respectively (Gutierrez, 2018). Furthermore, soup, paste, concentrate, juice, and ketchup which are an outcome of processed tomatoes conjointly contribute completely to human health (Bergougnoux, 2014).

## 2.7 Fertilizers

### 2.7.1 Mineral fertilizer

The use of mineral fertilizer for tomato production has been on for some time because farmers and other land users recognized the need to improve soil fertility for optimum production, (Mbah, 2006). Continuous deforestation, over-application of fertilizer, erosion, and loss of soil humus through harvesting are some of the causes of soil fertility depletion. However, to increase tomato production, there is a need to improve soil fertility management to reduce food scarcity and enhance food availability. Soil fertility, especially in the tropics, can be improved for optimum tomato production with the use of inorganic fertilizer in form of N.P.K. However, there are many demerits in the use of inorganic fertilizers such as leaching, increased acidity, high cost

of purchase, and hazardous effect on man and his environment among others (Tanimu et al., 2007). With all these negative effects of inorganic fertilizer on agricultural land and the environment, there is a need to explore alternative ways to improve soil fertility and ensure food security. Over the years, farmers and researchers are shifting to the use of organic fertilizers like compost, cow dung, and poultry manure (Usman, 2015). It is an age-long practice, it is generally accepted, technically feasible, commercially viable, relatively cheap, and improves soil physical properties and soil microbial population (Belay et al., 2001). It also increases soil nutrients and has little or no adverse effects on man and the environment (Tosun et al., 2001). Nutrients contained in organic manures are released more slowly and are stored for a long time in the soil; thereby ensuring residual effects on the succeeding crops (Ginting et al., 2003). In the world today, vegetable produced chemically is widely discouraged due to concerns about the potential negative impact on human health and the environment. Increasing consciousness concerning protecting the environment and the health hazards caused by agrochemicals has brought a significant shift in consumers' choice towards food quality, most especially in developed countries. Global customers are intentional about organic food that is thought-about to be safe and hazard-free. There is a steady increase in the demand for organically produced food both in developing countries and developed countries, with an annual average rate of 20–25%. Throughout the World, over 130 countries produce certified organic products in commercial quantities (Kortbech-Oiesen, 2000).

It was reported by (Joya et al., 2022), that three hundred batches of vegetables were blocked from being sold in Singapore due to the excessive use of pesticides. It was reported that about 3-5% of Malaysian vegetables and fruits have exceeded the pesticide limits set by the Singaporean authorities. Similarly, in 2017, fruits and vegetables from Cameron high land also were rejected from China due to the presence of excessive levels of pesticides (Joya et al., 2022). (Ekelund and Tjarnemo, 2004) reported that tomatoes are grown using conventional and organic fertilizers and recently there is an increase in demand for the organically grown product due to the common belief among consumers that organic products are healthier than



conventional products although (Huuml et al., 2011). says research result remains inconclusive.

### **2.7.2 Organic fertilizer**

(Assefa and Tadesse, 2019), Stated that organic fertilizers are made from biodegradable organic substances, as a result, any chemical that occurs naturally and is easily biodegradable is organic, and any organic element that improves the soil's richness is referred to as organic fertilizer. Numerous microorganisms further break down or decompose organic compounds into smaller soluble particles These fertilizers are absorbed by the roots after being converted into soluble and simpler chemicals. The use of organic fertilizer is a long-standing practice that's widely accepted, technically practicable, commercially successful, and reasonably inexpensive, and it enhances soil physical characteristics and microbial population (Belay et al., 2001). It also enhances soil nutrients while having minimal to no negative effects on people or the environment (Rugchat, 2021). Organic manure nutrients are released more slowly and are kept in the soil for a longer period, ensuring residual effects on subsequent crops (Diacono and Montemurro, 2011).

Organic fertilizer can help to boost soil fertility and productivity (Haque et al., 2021; Verma et al., 2020). Organic materials such as animal manure, plant residue, and composted organic matter have been shown to boost food crop productivity and quality (Khosro et al., 2011). Low levels of plant nutrients are included in the materials, which are steadily released over time. However, the availability of these materials, as well as their bulkiness, which raises transportation costs, and closeness to the point of application, limit their utilization. Farmers are expecting a proper solution to agricultural concerns that does not compromise production. So, organic fertilization methods are largely regarded to be more environmentally friendly and produce slower but consistent results. The use of organic fertilizers is now considered to be a significant advancement in the field of agriculture (Mondal et al., 2014).

## 2.8 Irrigation

Irrigation can boost crop yields, lower yield variability, and boost profits. However, selecting and purchasing an irrigation system is both complex and costly. Farmers must consider several major factors when investing in an irrigation system, these factors include water availability, the system's application efficiency, distances from which the water must be pumped, or pumping lifts, operating pressure of the layout, financing field operations savings, sources of energy, energy prices, crop, the economy of scale, availability of labor and price of the commodity (Amosson et al., 2002). Water scarcity is increasing because of changing rainfall patterns caused by climate change, as well as increased water use by a growing population and increased industrial production. Agriculture, on the other hand, is by far the largest water user on the planet, accounting for 69% of freshwater use (Pltonykova et al., 2020). At the same time, even though only 20% of agricultural land is irrigated, the contribution of irrigated agriculture to global food production is estimated to be 40% (Kirby et al., 2017). As a result, irrigated agriculture is the only way to maintain the current level of food supply. The use of water-saving irrigation is required to boost food production and reduce water scarcity. During the dry season, irrigation is important by selecting crops, irrigation systems, and management practices wisely, water in a wide variety of quantities can be used for irrigation (Easter and Welsch, 2019). Since the tomato plant is particularly susceptible to water stress, (Lopes et al. 2005) stated that good productivity necessitates the availability of water throughout the cycle. Throughout the growing period, until fruiting, the crop requires sufficient water. Williams (Williams, 1991). Low rainfall makes crops reliant on irrigation, as lack of water has a significant impact on the quality and amount of output (Pires et al., 2009).

### 2.8.1 Drip Irrigation

Drip irrigation has become a viable alternative among the various irrigation systems used in tomato growing (Marouelli et al., 2011) because of its many advantages, including the ability to grow in areas with limited water availability, high levels of efficiency (Monte et al., 2013), and lower incidence of diseases of plant aerial parts, resulting in high yield and fruit quality. Although drip irrigation demands a large

initial financial investment, it is one of the most effective methods for applying water to vegetables and orchards (Cetin and Uygan, 2008). Drip irrigation can boost plant output, reduce evapotranspiration, and save water and fertilizer (Ozbahce and Tari, 2010). Furthermore, its pumping takes less energy, can reduce negative irrigation impacts on soil, and it makes fertigation easier. (Monte et al., 2009). Drip irrigation boosts production and enables efficient irrigation of fields that are difficult to irrigate by other methods due to slope or soil characteristics. Irrigation management is very complicated in locations where there is a shallow, saline water table. Drip irrigation preserves productivity in this area by keeping the root zone mostly salt-free, and drip irrigation's high efficiency reduces the amount of drainage water generated (Hartz et al., 2008). Weather-based reference evapotranspiration ( $ET_0$ ) estimations and crop growth stage dictate drip irrigation requirements. The frequency of irrigation might range from once or twice a week early in the season to daily irrigation during periods of high-water demand.

#### 2.8.2 Eco tube irrigation (porous pipe)

Porous pipes rely on an ancient way of delivering water using clay pots, which were first utilized in the Middle East. Water is applied to the soil through a porous substance that is in contact with the surrounding soil material, according to the working principle. When plants use water, the drying soil's matric potential rises, and the potential gradient causes the water to migrate. Clay pipes were designed based on clay pot irrigation technology, making water supply to the field more efficient (Akhoond-Ali and Golabi, 2008). Clay materials, on the other hand, are brittle and susceptible to soil erosion and decomposition. The material is heavy and labor-intensive to install because of the large diameters employed. As a result, synthetic materials are now used to make porous pipes to stimulate water passage from the pipe to the surrounding soil material, a porous pipe system is operated at low pressure. Water-logging-like situations are avoided, and because the entire pipe works as an emitter, changes in water content are formed solely along the line (Siyal and Skaggs, 2009). As a result, if the porous pipe is properly positioned beneath the crop row, water and oxygen supply should be optimal throughout the irrigation cycle.

Porous pipes have not been widely used in irrigated agriculture. The lack of adequate materials made porous pipe systems deteriorate quickly and reduced the uniformity of water application. Furthermore, the lack of adoption of porous pipes is due to the need for high-quality water and the demand for permanent subsurface installation, which interferes with other on-farm management operations, such as soil tillage.

## 2.9 Factors affecting the quality of tomato fruit

### 2.9.1 Temperature

Tomatoes do not tolerate frost and require a warm temperature to grow. In cultivation, the typical life cycle is one spring and one summer. Its ideal temperature is roughly 26°C during the day and 12°C at night. Plants need temperatures above 18°C to grow vegetatively, but they can also thrive at lower temperatures (12°C). Flower fertilization, plant development, and fruit ripening all slow down at temperatures above 31°C. The ideal temperature ranges required at different phases of tomato development are listed in table 2 below, which was adapted from (Geisenberg and Stewart, 1986).

**Table 2** Temperature Range

Source: (Victoria et al., 2011)

Stages of development	Temperature (°C)		
	Minimum	Optimum	Maximum
Germination	11	15-30	30
Vegetative growth	18	20-24	30
Fruit set night	10	14-20	24
Fruit set day	18	20-24	30
Red color development	10	20-24	30

### 2.9.2 Water

Soil water and nutrient quality are two significant environmental elements that affect the vegetative growth and reproductive phase of tomatoes. As a result, using the right irrigation and fertilization measures at the right time can significantly boost fruit yield. A variety of experiments have been conducted to examine the impact of soil water status on tomato yield and growth (Wang and Xing, 2017; Zhang et al., 2017; Zotarelli et al., 2009). (Preece and Peñuelas, 2016), found that tomato plants can adjust morphologically to both extremes of water scarcity and abundance. Both the crop roots' ability to detect soil–water status and the shoots' ability to adjust morphologically to the soil environment rely on improved root development and soil moisture conditions (Koevoets et al., 2016). This is because a healthy root system will aid plant nutrition intake as well as increase leaf area and dry matter (Ayi et al., 2016; Faucon et al., 2017). Waterlogged soil, on the one hand, reduces the rate of leaf elongation and dry-matter uptake by the shoots (Kano-Nakata et al., 2011). Water scarcity, on the other hand, causes plant roots to grow deeper in quest of water while also altering root morphology by diminishing lateral roots (Faucon et al., 2017; Romero-Aranda et al., 2001). Drought and waterlogging produced a considerable decrease in dry matter buildup, resulting in low fruit yields (Bisbis et al., 2018; Shao et al., 2016; Sharma et al., 2014).

### 2.9.3 Soil

Tomatoes thrive in a variety of mineral soils, but they prefer sandy loams that are deep and well-drained. In heavy clay-type soils, deep tillage allows adequate root penetration, allowing tomato production. Tomatoes are moderately tolerant of a wide pH range. (Worley, 1976) found that tomato yields were higher in soils with a pH of 6.5 to 6.9 when compared to acidic soils. Fruit size is reduced in soils with an acidic pH or high salt (Hazman et al., 2022). Tomato is a heavy feeder of nitrogen (N), phosphorus (P), and potassium (K) fertilizer and reacts well to fertilizer treatment (Xiukang and Yingying, 2016). Before applying fertilizer to the soil, a soil test must be conducted. A soil test determines which nutrients are currently present. Applying fertilizers without first analyzing your soil might lead to nutrient imbalances, resulting in plants that thrive



but do not produce any or a lot of fruit (Tonfack et al., 2009). According to (Nathan et al., 2012), Managing soil fertility and applying plant nutrients according to soil test recommendations will affect tomato quality and is necessary for harvesting abundant, tasty, and nutritious tomatoes.

P and K nutrition has been demonstrated in numerous studies to have positive effects on fruit sugar and acid content. When compared to low P conditions, high P application resulted in higher sugar content in tomatoes. It was discovered that increasing the amount of K increased the acid content of tomatoes. According to many studies, a modest amount of nitrogen will improve tomato flavor, while too much nitrogen would destroy the fruit. Fruit flavor can also be harmed by excessive N and K fertilization. According to research, when tomatoes are given enough K, they respond by creating more health-promoting carotenoids and red lycopene, which gives tomatoes their red color (Ilić et al., 2014).

### **2.10 Polytunnels**

Polytunnels are structures made of polyethylene, they are designed to protect a row of plants or a section of a garden. In temperate countries farmers can use it to extend their growing season without adding heat, allowing them to meet consumer demand for fresh market produce during times that are often off-season (Conner et al., 2010). The use of polytunnels can be used in the production of high-value crops including tomatoes, bell peppers, garlic, strawberries, blackberries, and raspberries (*Rubus* species and variants), as well as several kinds of cut flowers (Lamont, 2009; Orzolek et al., 2004). Farmer's markets and other direct marketing channels are expanding as year-round customer demand for fresh, regionally sourced, and organic produce increases (Zepeda and Deal, 2009), providing potential for growers to adapt and profit from the use of polytunnels. The use of polytunnels in production systems is ideal for organic farming because they are energy efficient and can improve vegetable quality and yield over field-grown systems. (Bisbis et al., 2018)

## CHAPTER 3

### MATERIAL & METHODS

#### 3.1 Study area

The study was carried out on Maejo university organic farm located at latitude 18°54'54.0"N longitude 99°03'25.7"E. The experiment was repeated twice during dry season and rainy season, respectively. During the rainy season, polytunnels were used. Figure 5 shows the location of Maejo University's organic farm.

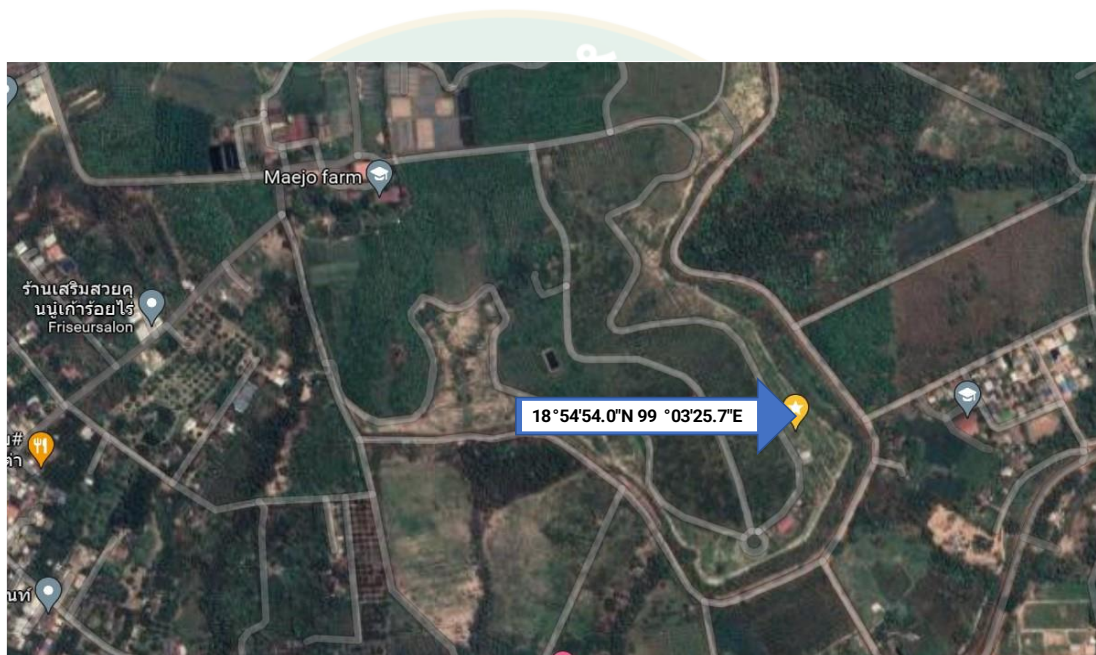


Figure 5 Location of Maejo university organic farm.

#### 3.2 Land preparation

The field was cleared and prepared into blocks, and ridges were made. Figure 6 shows the land preparation.





**Figure 6** Land preparation.

**Table 3** Chemical properties of soil from study area.

Soil properties	composition
pH	6.98
Organic Matter (%)	2.03
Available phosphorus	96.10
Exchangeable Potassium (mg/kg)	63.38

### 3.3 Varieties

There were 4 varieties used 3 organic varieties, and one hybrid. The organic varieties used are Eber, Tor, Sida, and hybrid (phetchompous Tok. Piyawan). The Eber Variety was gotten from Maejo University, Sida from Horticulture Research Center Sri Saket, Tor from Mae Ta, Green Net, and Hybrid from East west company.

### 3.4 Varieties and properties according to suppliers

#### 3.4.1 Eber

Eber variety is common in Thailand. It is a determinate type. It has a sour taste, the fruit of Eber usually ranges from red-orange, and they are usually small in size. The harvesting periods are usually 60-70 days after transplanting.

#### 3.4.2 Sida

Sida is a Thai salad tomato and one of the most popular tomato Varieties in Thailand the local name is "มะเขือเทศสีดา". Sida tomato is a determinate type, the plant reaches a height of 60-100 cm. The fruits are juicy, thick, and tight-textured. The average weight of the fruit is 20 grams. Fruits are red-colored, but they tend to color pink with a bit of green even when very ripe and have a slightly acidic taste. The average yield is 1.06 tons per hectare. It also has a high vitamin C content of 43.3 mg/100 g, more than the typical variety with only 14 mg/100 g of vitamin C. It also has an average acidic content of 0.93%, while the common varieties are only 0.2-0.5%. Suitable for use in cooking to have a sour taste, especially in papaya salad. The harvesting period is generally 75-90 days after planting.

#### 3.4.3 Tor

It was obtained from Mae Ta and Green Net they have large red fruits, fruitful, good weight, and taste, thick texture, eaten fresh, and can be used for cooking. prefers to be sunny and grows well in the winter but the plants must be exposed to enough sunlight for them to grow. They grow well in sandy loam soil with good drainage. They are suitable for outdoor planting and need proper spacing for them to grow well. Watering should be done regularly to ensure that the plant receives an adequate amount of water for growth. They are used for processing tomatoes in industries. Harvest is done 115 days-120 days after planting

#### 3.4.4 Hybrid (phetchompous Tok. Piyawan)

It is resistant to Bacterial wilt and TYLCV (Tomato yellow leaf curl Virus), it is a semi-determinate type, harvesting stage 60-65 days after transplanting, Fruit weight 20-25 grams/fruit, Yield 2-4 kg/plant.

**Table 4** The different Varieties and their uses.

English name	E-Ber	Sida	Tor	Tok Piyawan
Thai name	อีเป้อ	สีดา	ท้อ	เพชรชมพู ต้อก ปี ยะวรรณ
Use	Used for cooking and making soups.	Used for cooking, especially in papaya salad, it can be eaten raw,	Used for cooking, used in industries as processed tomatoes	Used for Cooking
Kind	Determinate	Determinate	Indeterminate	Semi-determinate

In this experiment, the hybrid variety was used as a control and the result from its interaction with other factors was compared with those obtained from the organic varieties.

#### 3.5 Seedling treatments and planting

Seeds were sown in the nursery for both the dry and rainy seasons on the 11<sup>th</sup> of February and 27<sup>th</sup> of May 2022 respectively. They were first sown in a basket that contained burnt husk/ charcoal and sand. The burnt husk helped to reduce humidity and the sand helped the root grow well. A week after germination, the seedlings were transferred into a tray containing coconut coir, Azolla, and compost at the ratio of 1:1:1. Irrigation was done twice a day but when the seeding leaves had started expanding the irrigation was reduced to once a day. For the dry season experiment at the point of transplanting, it was noticed that Tor was a bit slow in growth compared to every other variety. The tomato seedlings were hardened off a week before transplanting by doing, this introduces them to the temperature and sunlight outside



the greenhouse so that when the seedlings get to the open field there are not susceptible to sunburns.

Transplanting to the open field for both the dry and rainy seasons was done on the 13<sup>th</sup> of March 2022 and the 16<sup>th</sup> of June 2022, respectively. Replanting of dead plants was done on the 18<sup>th</sup> of March 2022, for the dry season of the experiment, and 24<sup>th</sup> of June 2022, for the rainy season. The irrigation system was used immediately except for eco tube irrigation which was delayed for a week before it began usage and this was done only during the dry season of planting. Figures 8 and 9 show the seedlings in the nursery and during the period of hardening off.



**Figure 7** Comparing seedlings in the tray 2 weeks after planting in the nursery.



**Figure 8** Seedlings in the greenhouse being manually irrigated.



**Figure 9** Hardening off of seedling before transplanting.

### 3.6 Irrigation management

#### 3.6.1 Drip irrigation

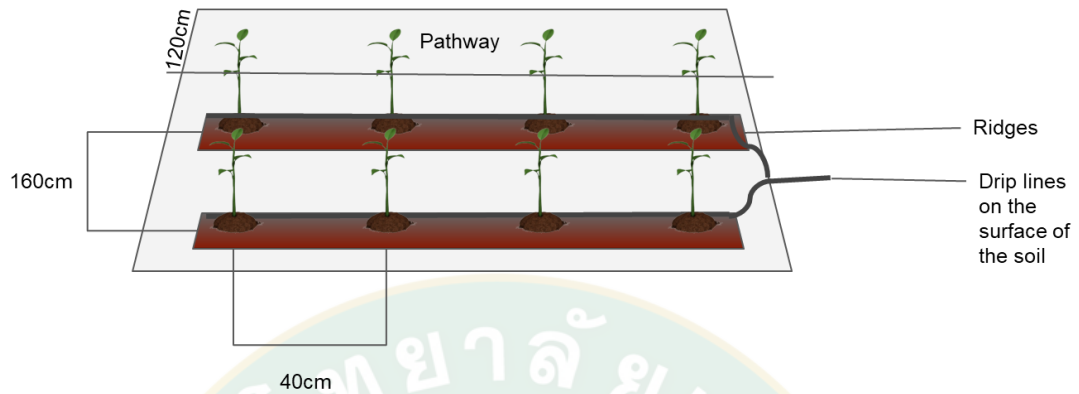


Figure 10 Drip irrigation.

#### 3.6.2 Eco tubes

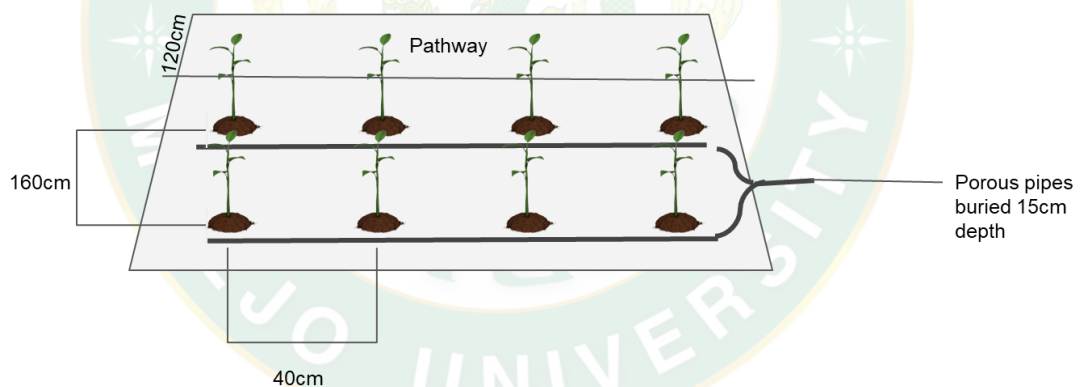


Figure 11 Eco tube irrigation.

Seedlings were planted on a double row at a spacing of 40 cm apart with 160 cm between the rows and then a pathway of 120 cm. But for the Rainy season, polytunnels were introduced. The polytunnels used, were made of steel but had polyethylene plastic covering the shape of the tunnels were semi-circular shaped with a width of 6 m wide and a length of 12 m long. Some bamboo sticks were also used



as support for the tunnels. Figures 12 and 13 are pictures of the polytunnels on the field.



Figure 12 Polytunnel installed on the field.



Figure 13 Polytunnel on the field

### 3.7 Starter fertilizer

For the dry season of planting, Starter fertilizer was used before planting was done the starter fertilizer was mixed with the soil on the respective blocks. The arrangement of the fertilizer was such that it was in a systematic pattern. The starter fertilizer was composted 10 days before transplanting. The fertilizer was heaped separately, and water was added to make it moist. On the heap, a little hole was made for aeration. After wetting properly this heap was covered to allow proper decomposition daily checking was done. The temperature was also checked using a data logger thermometer, the data logger ensured a composting temperature above 60° C for proper composting. For the rainy season, a fish fertilizer was used. 5 ml of fish fertilizer to 9 liters of water and was sprayed directly into the soil the application was at 3 stages the early stage, growth stage, and fruiting stage. The chemical composition of both organic fertilizers used is shown in tables 5 and 6.

**Table 5** Chemical composition of organic fertilizer used.

Type of organic fertilizer	Nitrogen (%)	Phosphorous (%)	Potassium (%)
Poultry starter fertilizer	1.88	3.16	0.02
Cow starter fertilizer	2.40	0.08	1.61

**Table 6 Chemical composition of fish fertilizer analysis**

Composition	Values
pH	5.21
Electrical Conductivity ( $\mu\text{s}/\text{cm}$ )	0.36
Nitrogen (%)	0.70
Potassium (mg/L)	29.08
Phosphorus (mg/L)	663.75
Sodium (mg/kg)	< 0.20
Calcium (%)	0.26
Magnesium (mg/L)	2.92
Iron (mg/L)	39.65
Manganese (mg/L)	1.54
Zinc (mg/L)	3.90
Copper (mg/L)	< 1.00
Boron (mg/L)	10.21
Sulphur (mg/L)	1.51

### 3.8 Location: Experimental design and layout

#### 3.8.1. Dry season experiment

The experiment had a 3-factorial design with 16 treatments. The factors were irrigation method, starter fertilizer supply, and tomato variety having 2, 2, and 4 levels, respectively. Treatments were arranged in a partially randomized design in four blocks, two of which were equipped with surface drip irrigation and two with Eco tubes. Each block was split into two halves with one half being fertilized with cow starter fertilizer and the other half with poultry starter fertilizer. On each half, the four varieties were randomly arranged in four plots, so that all treatments were replicated twice. The plot size was 3 x 5 m with three double lines of tomatoes with 12 plants. The two outer lines are the outermost plants and the central line served as border plants so 8 plants in the center line of each plot were used as experimental units. Thus, a total of 16 plants were analyzed per treatment. Table 7 below shows the details of treatments

used in dry season. Drip irrigation and eco tube irrigation on the field can be seen in figures 14 and 15 respectively.

**Table 7** Treatment details for the dry season of planting

Treatment	Starter fertilizer	Variety	Irrigation system
T1	Cow	Eber	Drip
T2	Cow	Sida	Drip
T3	Cow	Tor	Drip
T4	Cow	Hybrid	Drip
T5	Poultry	Eber	Drip
T6	Poultry	Sida	Drip
T7	Poultry	Tor	Drip
T8	Poultry	Hybrid	Drip
T9	Cow	Eber	Eco tube
T10	Cow	Sida	Eco tube
T11	cow	Tor	Eco tube
T12	Cow	Hybrid	Eco tube
T13	Poultry	Eber	Eco tube
T14	Poultry	Sida	Eco tube
T15	poultry	Tor	Eco tube
T16	Poultry	Hybrid	Eco tube





Figure 14 Drip irrigation system irrigation on the field.





**Figure 15** Eco tube irrigation system on the field

### 3.8.2 Rainy season experiment

The experiment had a 3-factorial design with 12 treatments, the factors were irrigation methods, the use of polytunnel, and tomato variety having 2, 2, and 3 levels respectively. Treatments were arranged in a partially randomized design in four blocks two of which were equipped with surface drip irrigation and two with eco tubes. Each block was split into two halves, one half having polytunnels and the other half without polytunnels. On each half, the 3 varieties were randomly arranged in six plots such that the treatment was replicated four times. The plot size was 3x5m with 3 double lines of tomatoes with 12 plants. The two outer lines are the outermost plants and the central line served as border plants so 8 plants in the center line of each plot were used as experimental units. Thus, a total of 12 plants were analyzed per treatment. Figures 16 and 17 show eco tube irrigation under polytunnels and, drip irrigation under the use of polytunnels. The details of treatments used in the rainy season are in table 8 below.



**Table 8** Treatment details for the rainy season of planting

Treatment	Cover	Variety	Irrigation system
T1	Polytunnel	Eber	Drip
T2	Polytunnel	Sida	Drip
T3	Polytunnel	Hybrid	Drip
T4	No polytunnel	Eber	Drip
T5	No polytunnel	Sida	Drip
T6	No polytunnel	Hybrid	Drip
T7	Polytunnel	Eber	Eco tube
T8	Polytunnel	Sida	Eco tube
T9	Polytunnel	Hybrid	Eco tube
T10	No polytunnel	Eber	Eco tube
T11	No polytunnel	Sida	Eco tube
T12	No polytunnel	Hybrid	Eco tube

**Figure 16** Eco tube irrigation under the use of polytunnels.



**Figure 17** Drip irrigation under the use of polytunnels.

**Table 9** Different factors used for the experiment.

The first season of planting (dry season)	levels		The second season of planting (Rainy season)	levels	
Irrigation	2	Drip irrigation Subsurface irrigation (ecotubes)	Irrigation	2	Drip irrigation Subsurface irrigation (ecotubes)
Starter fertilizer	2	Cow dung Chicken dung	Polytunnel	2	Polytunnel No Polytunnel
Varieties	4	Four tomato varieties: E-Ber Sida Tor Hybrid	Varieties	3	three tomato varieties E-Ber Sida Hybrid

### 3.9 Irrigation

The irrigation methods used were drip irrigation and subsurface irrigation (eco tubes). The sub-surface irrigation included the use of porous pipes that were buried underground at 15 cm into the soil the porous pipes allowed the emitting of water uniformly to the roots of the plants evenly. Irrigation of the plants with eco tubes was done at a pressure of 0.6 bars. The drip irrigation included the use of drip lines which

were placed at the surface of the soil it had emitters at a distance of 30 cm where the water was gradually dropping out to the surface of the soil. Figure 18 below shows a dripline emitting water to the tomato plant. figure 19 provides a view of the irrigation system offering a clear and detailed overview of its structure and components.



Figure 18 Dripline emitting water to the tomato plant.

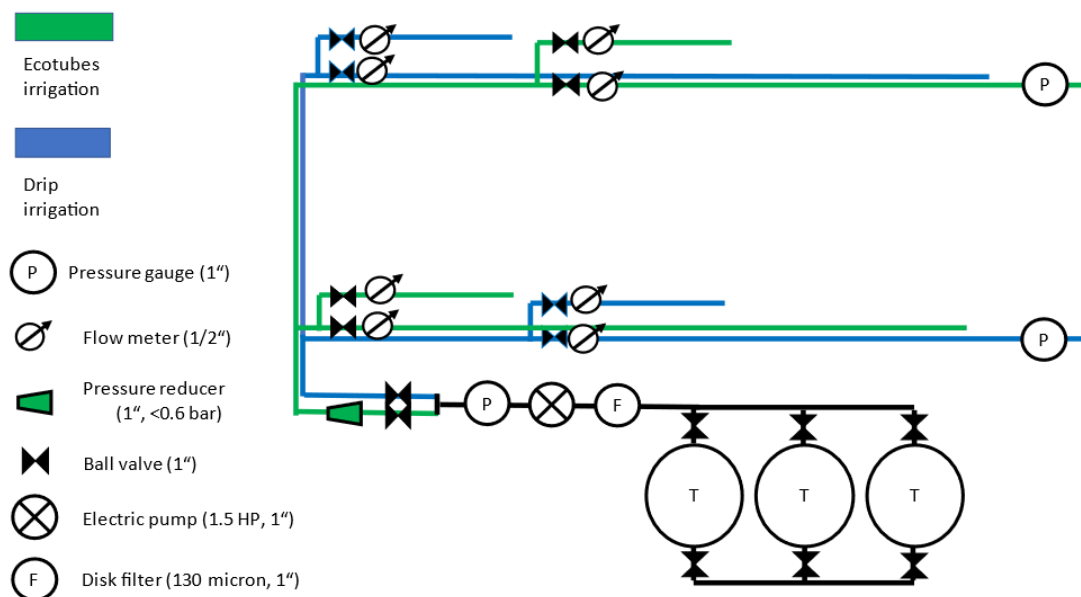


Figure 19 Overview of the irrigation systems.



There were 3 tanks on the field each containing 1,000 liters of water, At the inlet and outlet are filters (disc filter and mesh filter) these filters were installed to prevent debris and give good quality water to the field. These filters had to be cleaned regularly before irrigating the field to allow easy flow of water into pipes. There was also a pump on the field and a pressure gauge, the pump was connected to the electricity to supply water to the pipes leading to the irrigation system. The pressure gauge was used to monitor the pressure of the water. The diagram also shows the two piping systems, (drip irrigation and eco tube irrigation) pressure reducer was installed to prevent the outburst of pipes on the field. The eco tubes are recommended to operate at 0.6 bars this helps to reduce the pressure.

Flow meters were installed on the field, these flow meters were used to measure the amount of water supplied to the field, and at the end of each piping system, there was also a pressure gauge. Figures 20 and 21 show the setup of the irrigation system on the field.



**Figure 20** The tanks supplying water to the field.



Figure 21 The irrigation setup.

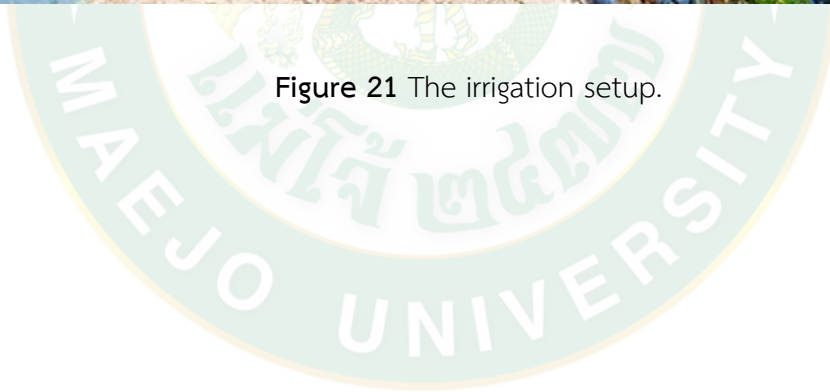






Figure 22 Disc filter and mesh filter.

### 3.10 Cultural practices

Three weeks after transplanting, the weeds on the field were handpicked on every block. And there was a consistent weeding every two weeks. Staking of the tomatoes was done 1 month after transplanting and this was done to give support to the plants for both seasons of planting pruning was also done. Staking done on the field is displayed in figure 23 below.





**Figure 23** Staking done on the field.

### **3.11 Pest and disease management**

Trichoderma was prepared in the lab and applied to the field 3 weeks after transplanting, this was done to control fungal disease it was sprayed directly into the soil. Beauveria was also applied to the field. Pesticide application was done with the use of neem oil and surfactant. the mixture was 15 ml of neem oil to 20 liters of water and the surfactant 10 ml to 20 ml of water. This was sprayed on the field using a knapsack sprayer. Throughout both seasons of planting pesticide was sprayed thrice. For the dry season of planting leaf curl disease and Bacterial wilt disease were noticed on the field every plant with this symptom was uprooted from the field and disposed of far from the field. For the second season of planting, bacterial wilt and Bacterial leaf spot disease were recorded. All plants with the symptoms were uprooted and disposed of far away from the field. Figure 24 shows the preparation of Trichoderma.

Figures 25 and 26 visually indicate the process of spraying the field, showing clearly how the task was done.



Figure 24 Preparing the Trichoderma before application.





Figure 25 Applying Trichoderma to the field.



**Figure 26** Spraying of the field using the knapsack sprayer.

### 3.12 Plant height measurement

The plant height of the tagged plants was measured weekly using a measuring tape. The measurements were taken from the soil surface to the tip of the highest leaf. To ensure there was consistency and accuracy the measurement of the plant height was taken by the same person. To take the measurement, the measuring tape was held perpendicular to the ground, and the zero point was placed at the soil surface. The tape was then extended to the tip of the highest leaf as shown in figure 27 below, and the measurement was recorded. The plant height data collected from these measurements were then used to analyze the growth rate and growth pattern of the plants over time.





**Figure 27** Plant measurement at an early stage of growth.

### 3.13 Harvesting

Harvesting started on the 6<sup>th</sup> of May 2022 and on the 2<sup>nd</sup> of August 2022 for the dry season of planting and rainy season of planting respectively. Eber varieties were the first to attain ripening then a week later Sida and hybrid were also harvested as well. For the dry season of planting, Tor plants were unable to survive on the field they all died before the time of harvest. After harvesting, the fruits were counted and weighed using a digital balance and classified into marketable and non-marketable fruits. For non-marketable fruits, it was classified based on cracked, BER (Blossom End Rot), underweight, and infested with worms and scabs. For some fruit to be marketable it had to be free from all these categories listed above and have its color looking good. The total fresh above-ground biomass was determined for each experimental plant. Subsequently, all plants were dried in a solar drier for 24 hours to obtain dry biomass.

### 3.14 Statistical analysis

Data collected were recorded by use of Microsoft Excel®. The different treatments were compared using the single factorial ANOVA at a significant level of 0.05.



**Figure 28** Tomato plant at flowering stage.





Figure 29 Complete flowering and early stage of fruiting.



Figure 30 Eber variety under drip irrigation with no polytunnel.





**Figure 31** Tomato plant under eco tube irrigation.

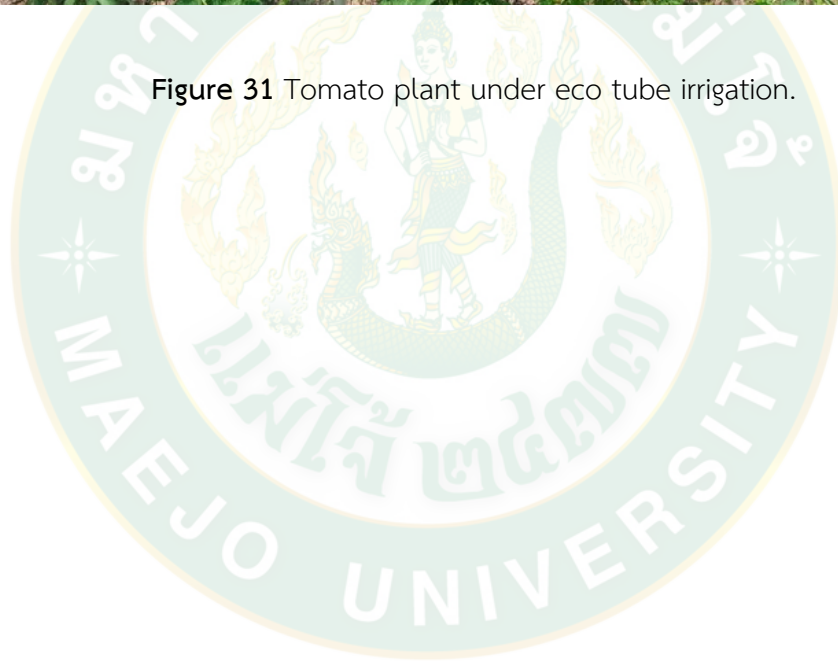




Figure 32 Hybrid variety with drip irrigation and polytunnels.





**Figure 33** Sida variety polytunnel and eco tube irrigation.





Figure 34 Fruit development in tomato plant.



Figure 35 Development of fruits.



Figure 36 Marketable Eber varieties and marketable Hybrid and Sida.



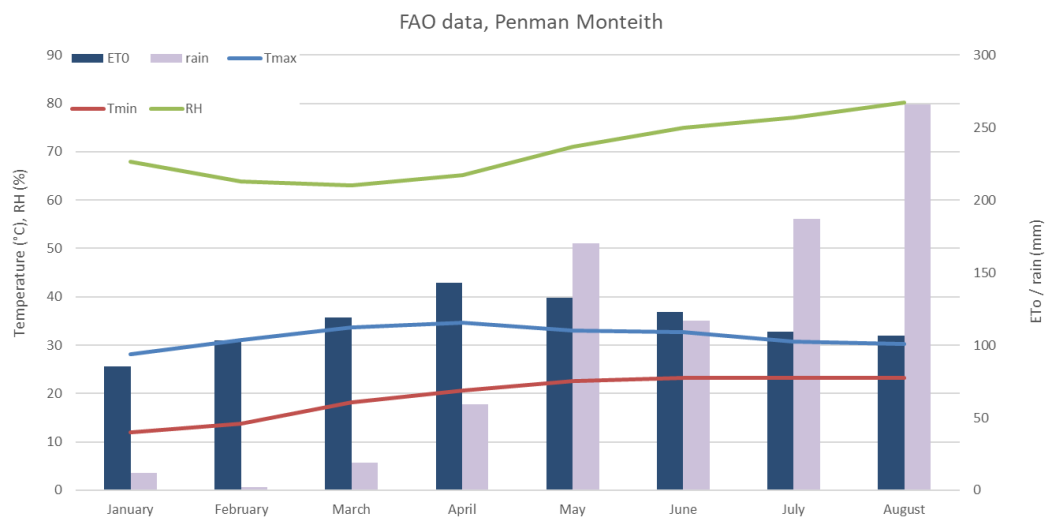
Figure 37 Biomass in a solar dryer.

### 3.13 Crop water requirement and irrigation scheduling

The initial irrigation scheduling was carried out based on the assessment of long-term mean climate data provided by the Food and Agricultural Organization of the United Nations (FAO) on the CLIMWAT database (FAO, 2022). Monthly data are provided on: maximum air temperature ( $T_{max}$ ), minimum air temperature ( $T_{min}$ ), mean

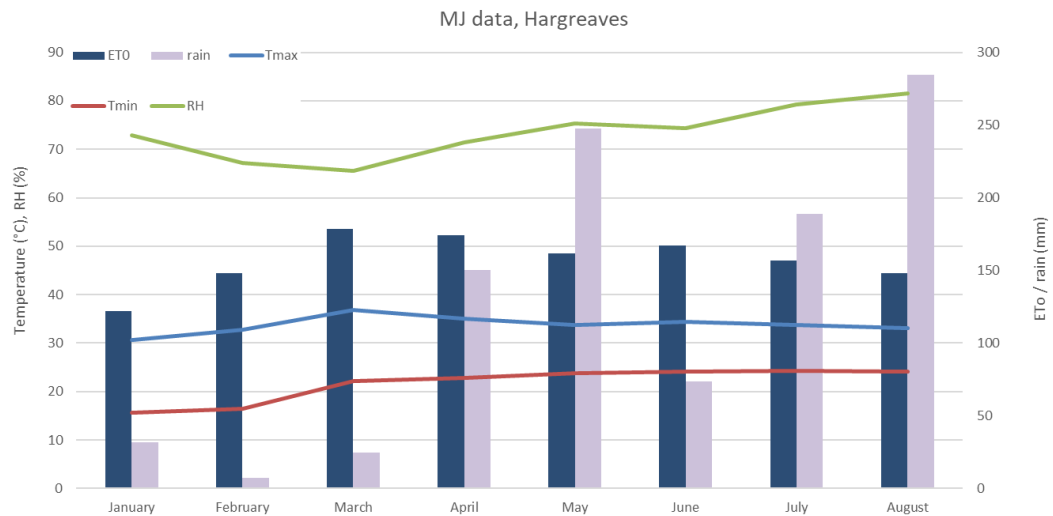


relative humidity of the air ( $RH_{avg}$ ), wind speed ( $u$ ), mean daily sunshine ( $R$ ). Based on the data available, reference evapotranspiration ( $ET_0$ ) was calculated using the modified FAO Penman-Monteith equation (Allen et al., 1998). Figure 38 below shows the initial estimation of  $ET_0$ .



**Figure 38** FAO climate data analysis for irrigation planning.

Weather data for the experimental period were obtained from the weather station of the Field Crop Research Center of the Agricultural Service of Chiang Mai Province. Available data were:  $T_{max}$ ,  $T_{min}$ , and RH.  $ET_0$  was estimated based on the Hargreaves method (Hargreaves and Samani, 1982). The resulting estimation of  $ET_0$  was used to adjust the irrigation in the experiment.



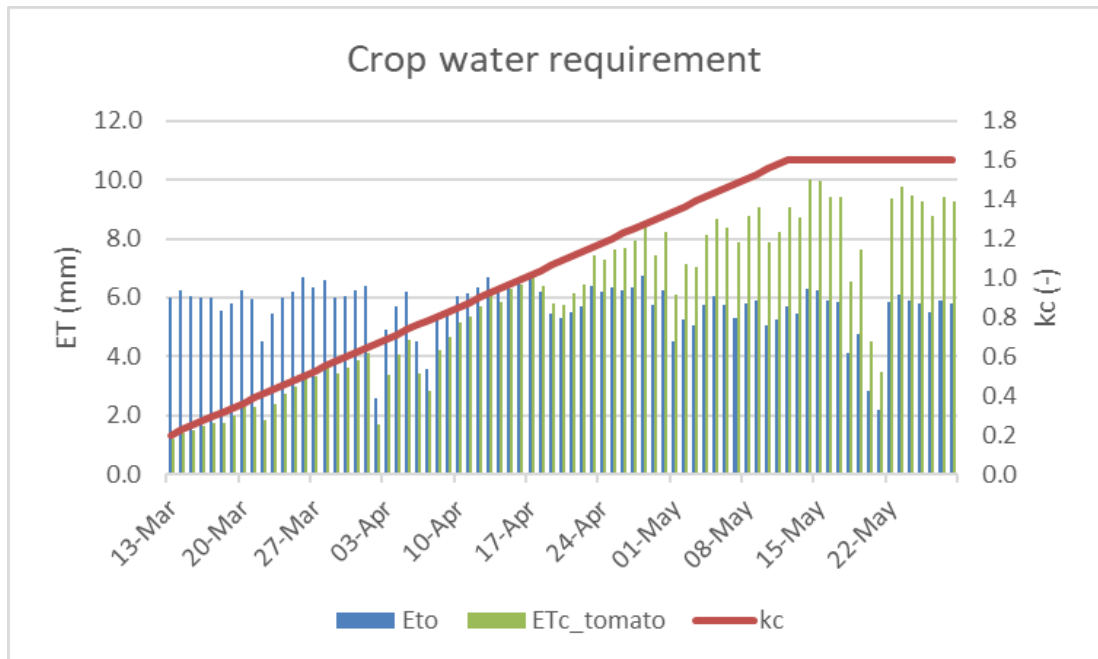
**Figure 39** FAO climate data analysis for irrigation planning

Based on the climate data, the crop water requirement (CWR) was calculated based on equation below:

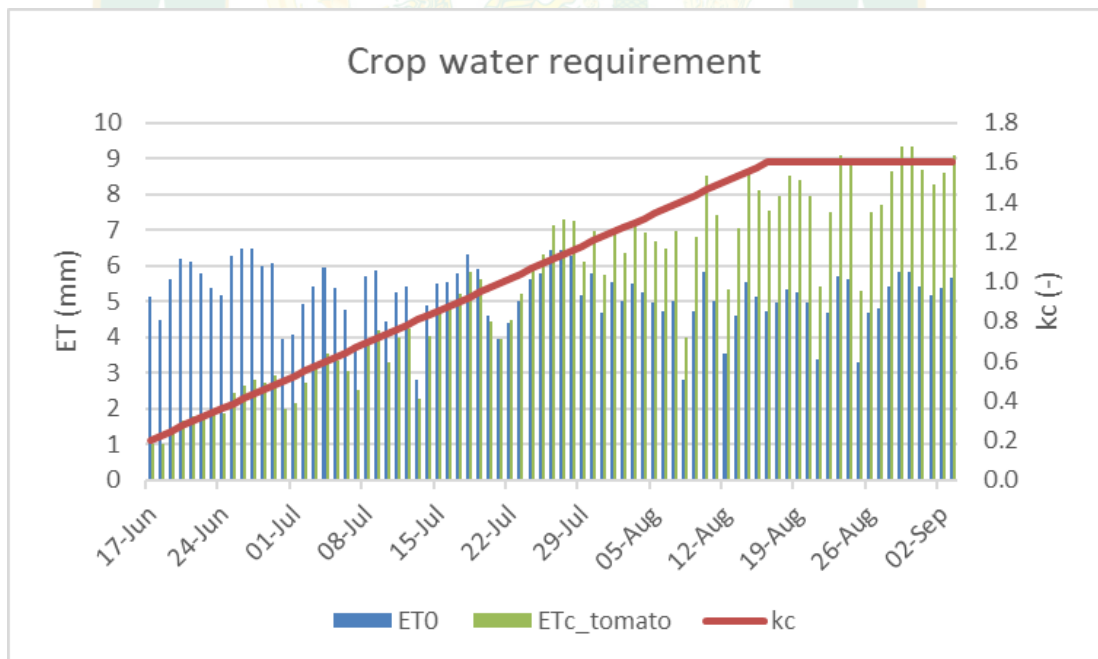
$$ET_{c\_tomato} = ET_0 * kc \quad \text{Equation 1}$$

Where  $ET_{c\_tomato}$  is the potential crop evapotranspiration of a tomato crop, which was considered equivalent to CWR. The crop coefficient ( $kc$ ) was assumed to be 0.2 for the initial phase after transplanting and 1.6 after the full development of the tomato crop after 60 days (Allen et al., 1998). A linear increase for the time of crop development was assumed, resulting in the CWR values for the experimental period displayed in Figures 40 and 41 below.





**Figure 40** Crop water requirement (CWR) for the experimental period.



**Figure 41** Crop water requirement (CWR) for the experimental period.

## CHAPTER 4

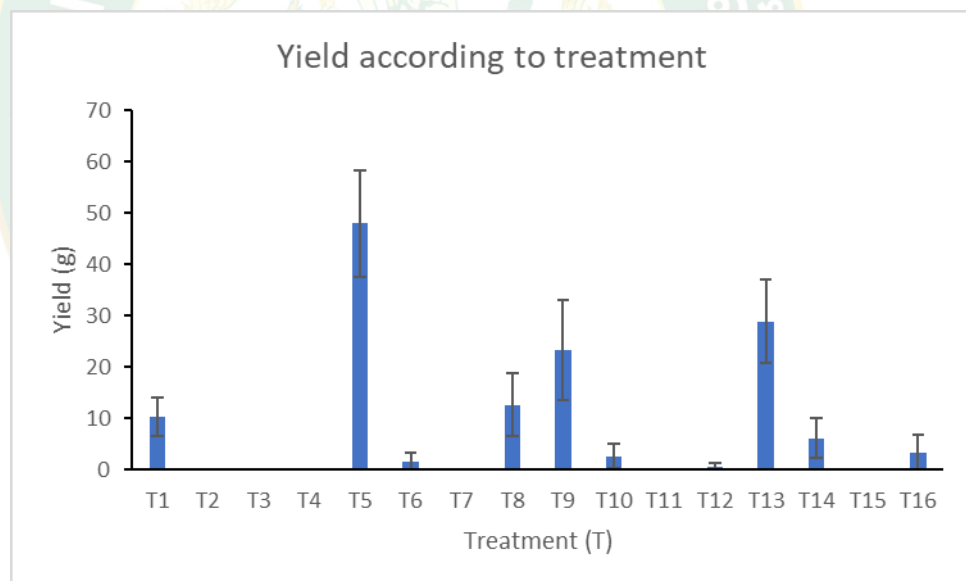
### RESULTS AND DISCUSSION

#### 4.1 Yield performance according to treatment in the dry season

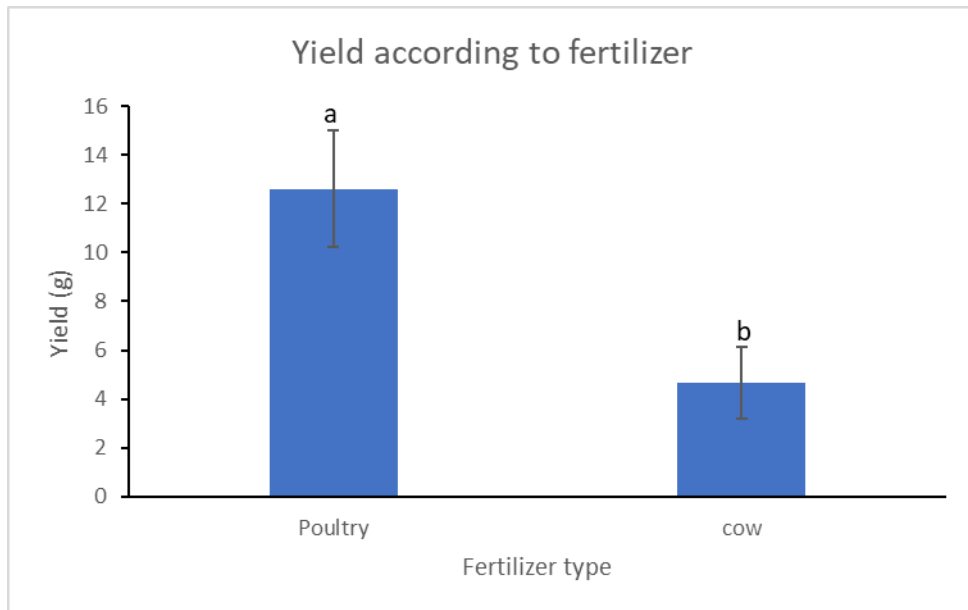
Figure 42 below shows the various combination of treatments used during the dry season experiment, this shows clearly that the highest yield was obtained in T5 (Poultry starter fertilizer, Eber variety, and drip irrigation) while the least yield was obtained in T15 (Poultry starter fertilizer, Tor Variety, and eco tube irrigation). From the various treatment combinations used, higher yields were obtained from the varieties that had poultry starter fertilizer applied. The higher yield obtained is attributed to the adequate release of essential nutrients, particularly nitrogen, phosphorus, and potassium, present in the poultry starter fertilizer, which has been found to significantly enhance crop growth and yield. Despite the higher nitrogen content observed in the cow starter fertilizer used in this research, the yield was low, this is because the nitrogen in the fertilizer is often bound up in complex molecules that are not easily accessible to plants. (Kwon, 2019) Conversely, poultry starter fertilizer contains readily available forms of nitrogen, which can be easily taken up by plants, resulting in more efficient use of the available nitrogen and ultimately higher yields. (Smith and Jones, 2019). The result is consistent with the findings of (Wang et al. 2019), who reported that poultry manure led to higher yields and nitrogen use efficiency when compared to cow manure.

According to Aiyelaagbe et al., (2005) and Katung et al., (2005) who stated that poultry starter fertilizer is known to provide the soil with adequate nutrient level and promotes rapid vegetative growth. During the experiment, it was observed that plants treated with poultry starter fertilizer had more healthy foliage compared to those treated with cow starter fertilizer, this is because of the adequate amount of nitrogen in the poultry starter fertilizer. (Barman et al., 2018) state that nitrogen is a component of the chlorophyll molecule, which gives plants their pigmentation associated with healthy growth, and foliage and it is involved in photosynthesis. However, dead plants had to be replanted under plants grown with poultry starter fertilizer because high

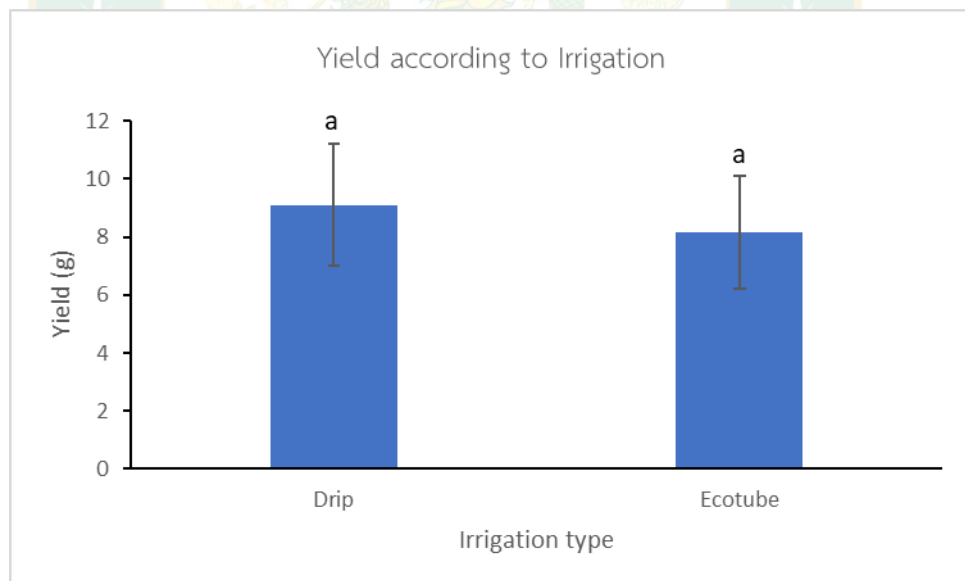
quantity was seen to damage the young seedlings. Furthermore, it is seen that the highest influencing factors on the yield were the poultry starter fertilizer and drip irrigation. Comparing the two methods of fertilizer used poultry starter fertilizer had more influence on the yield of the tomato varieties in comparison with cow starter fertilizer which is shown in figure 43 below. In the two irrigation systems used, there was no significant difference between the yields. This is due to the direct application of water near the root zone, which increases crops' ability to use water for growth while minimizing evaporation losses and leaching. As a result, leading to a Yield increase in both systems of irrigation. Regardless of the treatment combination used, the Eber variety consistently outperformed other varieties in terms of yield, demonstrating its superior productivity and potential as a high-yielding and reliable crop for the dry season.



**Figure 42** Yield according to treatment combination in the dry season.



**Figure 43** Yield according to starter fertilizer in the dry season.  
a, b= indicates significant difference at  $P < 0.05$ .

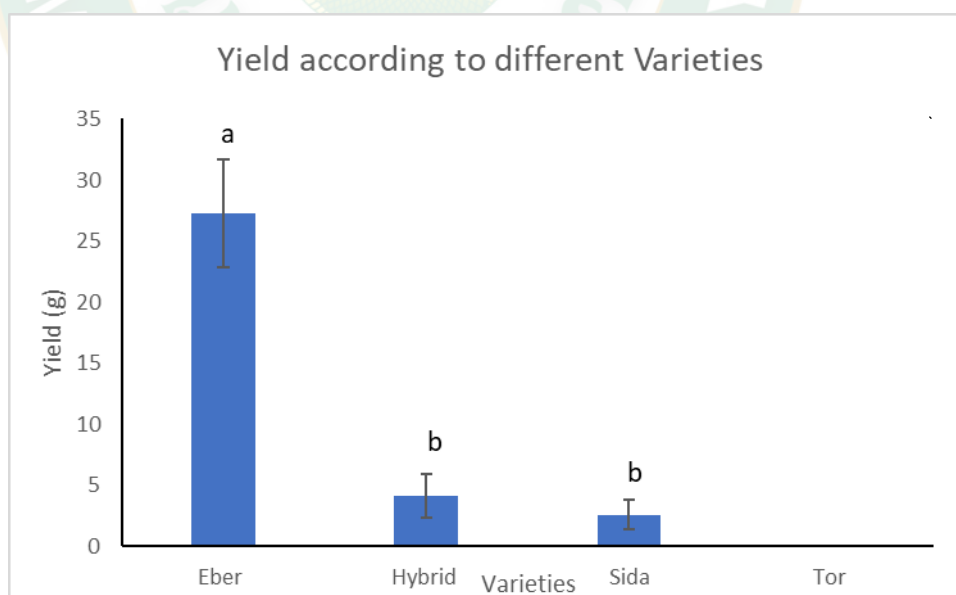


**Figure 44** Yield according to the different irrigation systems in the dry season.  
a, a= indicates a significant difference at  $P < 0.05$



#### 4.2 Crop yield performances According to Varieties in the dry season.

According to the results of the dry season experiment, the Eber (E) variety produced more yield than the hybrid (H), Sida (S), and Tor (T) varieties. Figure 45 below, illustrates that there was no difference in the yield between hybrid and Sida varieties. Eber recorded  $\pm 25.25$  g, Sida  $\pm 2.58$  g, and hybrid  $\pm 4.13$  g. The outstanding performance of the Eber variety can be explained by its ability to withstand pest infestation and harsh weather conditions which were not observed in the hybrid variety, Sida variety, and Tor variety. During the dry season, the combination of low rainfall and high humidity levels can lead to reduced yields in tomato plants. However, Eber variety showed a higher yield compared to other varieties due to its adaptability to these conditions. As a local variety, Eber variety developed traits that enable it to better withstand the effects of low rainfall and high humidity, making it a valuable option for Organic farmers looking to improve their tomato yields in the dry season. When the fruit sizes of the different varieties were compared, it was observed that the irrigation system or the starter fertilizer did not influence the size of the fruit; rather, the size of the fruits was determined by genetic characteristics.



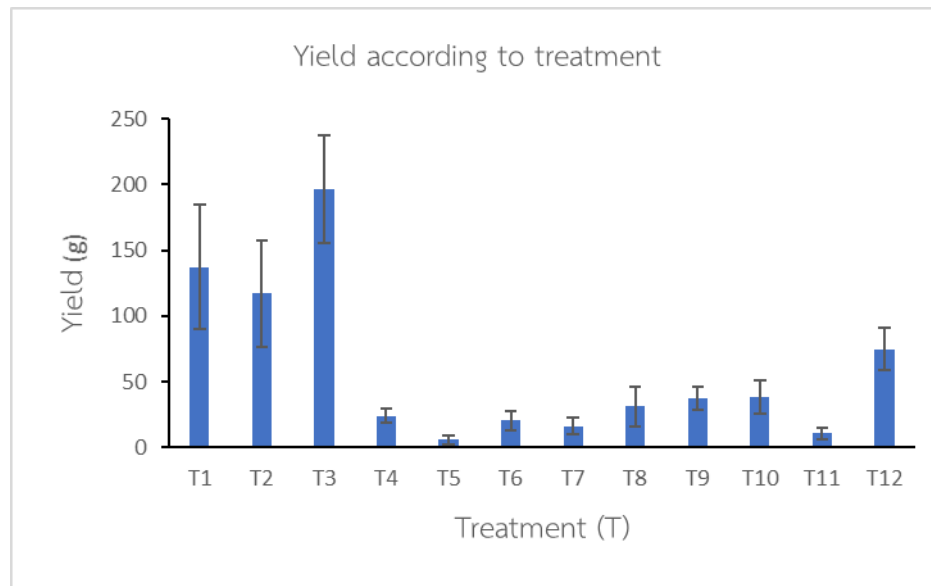
**Figure 45** Yield according to the different varieties used in the dry season.

a, b= indicates a significant difference at  $P < 0.05$

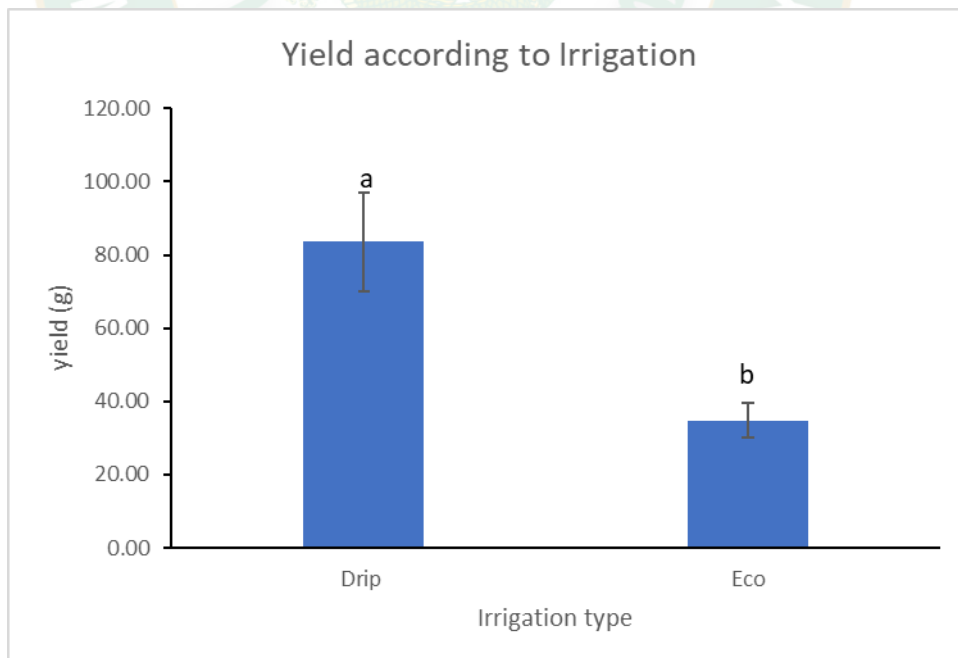
### 4.3 Yield performances according to treatment in the Rainy Season

Polytunnels were introduced in the rainy season experiment, these polytunnels were used to protect the plants against direct rainfall, and wind damage, and prevent injury from insects and diseases. In figure 46, the different treatment combinations are shown. T3 represents the treatment combination of polytunnels, hybrid variety, and drip irrigation, T1 represents polytunnels, Eber variety, drip irrigation, T2 polytunnel, Sida variety, and drip irrigation, and T5 represents no polytunnel used Sida variety, and drip irrigation. It was observed from the result that the highest yield was obtained in the treatment combination of T3 and the least yield was obtained in T5. The use of polytunnels in tomato production has been found to increase yield, according to the findings of (Rogers and Wszelaki, 2012). This increase in yield can be attributed to the reduction of pests and diseases in organically grown tomato plants, as demonstrated by (Baysal et al., 2009). These results suggest that the use of polytunnels can be an effective method for improving tomato yields, especially in organic farming systems where chemical control of pests and diseases is restricted. As expected, the highest influencing factor on yield in this season was the use of polytunnels compared to no polytunnels. Observations made during the experiment showed that tomatoes grown without the polytunnels had a higher incidence of pests and diseases due to excess rainfall. The absence of an irrigation system in the non-polytunnel system likely exacerbated this issue. These findings highlight the importance of protective structures like polytunnels and adequate water management in mitigating the negative effects of excess rainfall on tomato crops, ultimately leading to better yields. Moreover, the presence of polytunnels has been shown to provide additional benefits beyond reducing the incidence of pests and diseases, such as regulating temperature and humidity, extending the growing season, and protecting plants from adverse weather conditions. Drip irrigation appears to have contributed to the high yield in this planting season as well. This is shown in figure 47 below as significantly higher yields were obtained from the use of drip irrigation compared to eco tube irrigation. This exceptionally higher yield in drip irrigation can be explained by the adequate amount of water delivered to the plant root zone and ensuring water was saved efficiently. This was not the case with eco tube irrigation as water loss was high, which can be

attributed to the high rainfall that resulted in significant runoff under this system of irrigation.

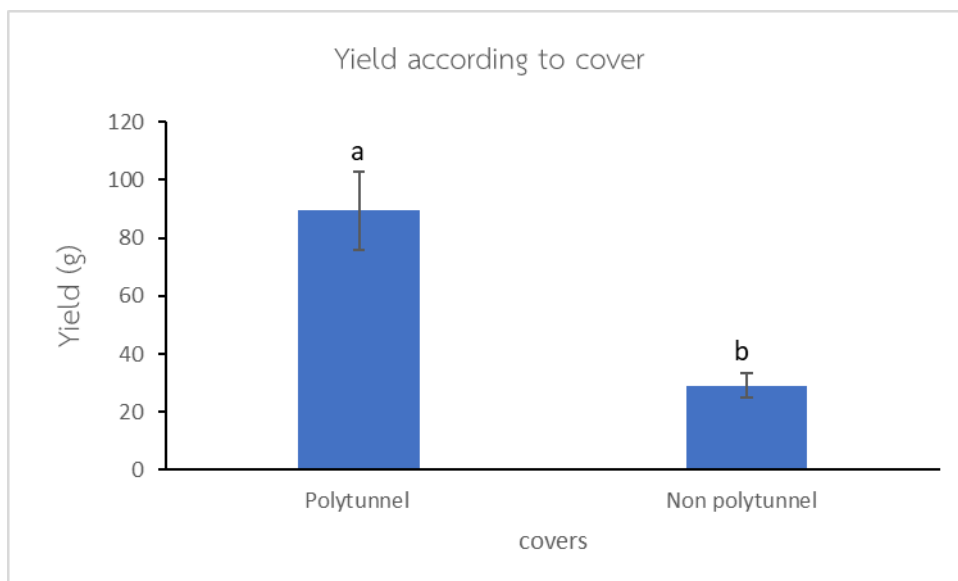


**Figure 46** Yield according to treatment combination in the rainy season.



**Figure 47** Yield according to the two irrigation systems in the rainy season.

a, b= indicates significant difference at  $P < 0.05$ .



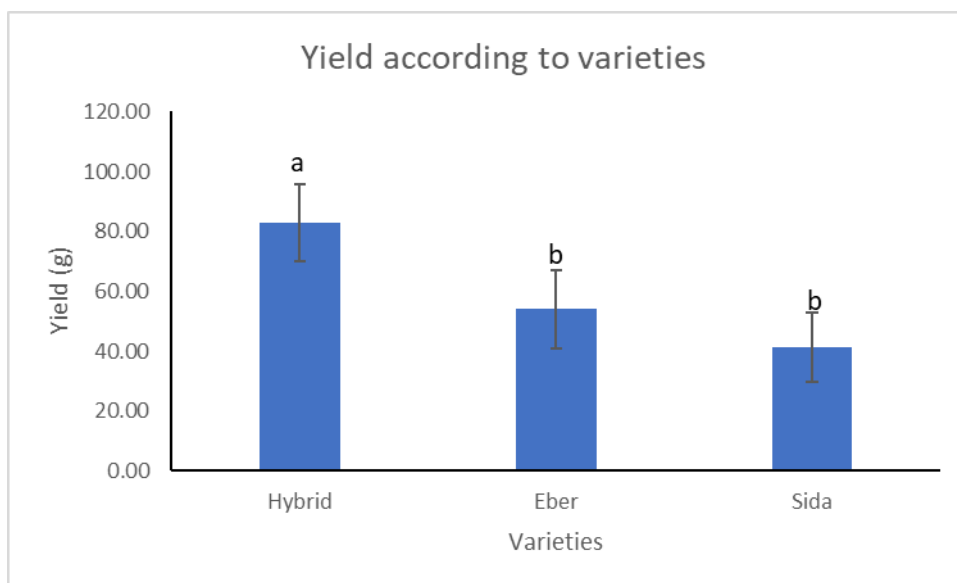
**Figure 48** Yield according to the use of polytunnels and no polytunnels in the rainy season.

a, b=indicates significant difference at  $P < 0.05$ .

#### 4.4 Crop yield performances According to Varieties in the Rainy season

The rainy season experiment carried out showed that there was no difference between the yield obtained from Eber (E) variety and Sida (S) variety as compared to hybrid (H) variety, this is shown in figure 49 below. The hybrid variety weighed  $\pm 82.8$  g, Eber weighed  $\pm 53.9$  g, and Sida  $\pm 41.2$  g. Although a control plant, the hybrid variety performed better in this season. This was because, although the rainfall had a detrimental impact on the eco tube irrigation, the hybrid variety established a good root system and maintained vigorous growth even when affected by pests and diseases.





**Figure 49** Yield according to different varieties used in the rainy season.  
a, b= indicates significant difference at  $P < 0.05$ .

#### 4.5 Irrigation analysis for dry season

Comparing the overall yield obtained in the dry season there was no difference between the use of drip irrigation and eco-tube irrigation. However, looking closely at the treatment combinations shown in tables 10 and 11 below, there was a higher water use efficiency in eco tube irrigation as compared to drip irrigation. This agrees with the result of (Kunze et al., 2021), who recorded a higher water use efficiency in the use of eco tube irrigation compared to the use of drip irrigation in their experiment. This is because Irrigation with eco tube at standard pressure consistently uses less water than other irrigation systems, making it the most water-saving method. This is consistent with the findings of (Prabhakar and Rank, 2022), who discovered a 26% increase in WUE, attributing this to the fact that no moistening of the soil surface occurred and evaporation was avoided. Thus, applying water and nutrients using the porous pipe irrigation system thereby improves water use efficiency and minimizes evaporation loss (Xiukang and Yingying, 2016). From the result, it was observed that a higher yield was obtained under the use of drip irrigation which can be explained by

the higher irrigation water used by this system. This is in line with the finding by (Xiukang and Yingying, 2016), who discovered increasing irrigation levels increased the yield of the tomato plant. (Biswas et al., 2016), similarly recorded increased tomato yield with an increased water supply without mulch as well. In the rainy season, there was a clear difference in yield between drip irrigation and eco tube irrigation. Drip irrigation had a better performance than eco tube irrigation in terms of yield. Water use efficiency was significantly higher in drip irrigation compared to eco tube irrigation. This is shown in tables 12 and 13. The high rainfall this season, combined with the subsurface installation of the eco tubes without dams to provide a firm hold to the plant, resulted in a high runoff, lowering yield under the eco tube system. This explains why eco tube irrigation performed poorly. Furthermore, with drip irrigation crops were planted on dams, which provided a firm hold less irrigation water was applied, and water was saved. There was an introduction of polytunnels, and as expected the use of polytunnels influenced the yield as more yields were produced compared to no polytunnels. From the result higher nonmarketable yield was obtained under no polytunnel as a result of excess water, pest, and disease leading to most of the fruit under this system cracked, spilled, diseased, and infested with worms.

**Table 10** Irrigation analysis for Eber and Sida varieties in the dry season.

E-ber		poultry		cow	
		Drip	Eco	Drip	Eco
Marketable yield	t/ha	3.00	1.80	0.65	1.46
Non-marketable yield	t/ha	5.59	3.95	1.58	2.22
Above-ground green biomass	g/plant	40.13	11.88	7.73	6.05
Irrigation water applied	mm	92.65	79.04	92.65	79.04
Water use efficiency (total yield)	kg/m <sup>3</sup>	9.28	7.28	2.41	4.66
<b>Sida</b>					
Marketable yield	t/ha	0.10	0.39	0.00	0.17
Non-marketable yield	t/ha	3.17	2.69	1.94	0.99
Above-ground green biomass	g/plant	17.37	11.76	9.59	0.81
Irrigation water applied	mm	92.65	79.04	92.65	79.04

Water use efficiency (total yield)	Kg/m <sup>3</sup>	3.53	3.89	2.10	1.46
------------------------------------	-------------------	------	------	------	------

**Table 11** Irrigation analysis for Hybrid and Tor varieties in the dry Season.

Hybrid		poultry		cow	
		Drip	Eco	Drip	Eco
Marketable yield	t/ha	0.80	0.21	0.00	0.04
Non-marketable yield	t/ha	9.25	9.39	1.94	0.88
Above-ground green biomass	g/plant	39.28	43.53	12.41	0.48
Irrigation water applied	mm	92.65	79.04	92.65	79.04
Water use efficiency (total yield)	kg/m <sup>3</sup>	10.84	12.16	2.09	1.16
<b>Tor</b>					
Marketable yield	t/ha	0.00	0.00	0.00	0.00
Non-marketable yield	t/ha	0.00	0.12	0.00	0.00
Above-ground green biomass	g/plant	16.39	1.71	1.21	1.97
Irrigation water applied	mm	92.65	79.04	92.65	79.04
Water use efficiency (total yield)	Kg/m <sup>3</sup>	0.00	0.15	0.00	0.00

**Table 12** Eber and Sida irrigation analysis in the rainy season.

E-ber		polytunnel		no tunnel	
		drip	ECO	drip	ECO
Marketable yield	t/ha	8.80	1.03	1.50	2.38
Non-marketable yield	t/ha	4.99	0.61	5.57	3.43
Above-ground green biomass	g/plant	12.69	4.84	10.23	6.93
Irrigation water applied	mm	159.5	161.6	159.5	161.6
Water use efficiency (total yield)	kg/m <sup>3</sup>	14.89	2.07	7.63	7.35
<b>Sida</b>					
Marketable yield	t/ha	7.31	1.95	0.39	0.67
Non-marketable yield	t/ha	2.61	0.77	2.72	1.15
Above-ground green biomass	g/plant	21.27	7.78	6.67	1.72
Irrigation water applied	mm	159.5	161.6	159.5	161.6
Water use efficiency (total yield)	kg/m <sup>3</sup>	10.70	3.43	3.35	2.30

**Table 13** Hybrid irrigation analysis in the rainy season.

Hybrid		polytunnel		no tunnel	
		drip	ECO	drip	ECO
Marketable yield	t/ha	11.96	2.35	1.28	4.67
Non-marketable yield	t/ha	6.11	1.90	3.33	2.85
Above-ground green biomass,	g/plant	31.19	11.15	9.93	10.13
Irrigation water applied	mm	159.5	161.6	159.5	161.6
Water use efficiency (total yield)	Kg/m <sup>3</sup>	19.50	5.38	4.97	9.52

**Table 14** Maximum and minimum temperature, the relative air humidity, amount of rainfall, and reference crop evapotranspiration in both rainy and dry seasons.

month	Max temperature ( $t_{max}$ ) (°C)	Min temperature ( $t_{min}$ ) (°C)	Mean rel. humidity ( $RH_{avg}$ ) (%)	Rain (mm)	ET <sub>0</sub> (mm/day)
January	30.6	15.7	72.8	31.5	4.1
February	32.8	16.5	67.1	7.4	4.9
March	36.8	22.1	65.5	24.5	5.9
April	35.1	22.9	71.5	150.3	5.8
May	33.8	23.7	75.4	247.4	5.4
June	34.5	24.1	74.4	73.8	5.6
July	33.7	24.3	79.3	188.9	5.2
August	33.0	24.1	81.5	284.5	4.9

#### 4.6 Plant Height According to Varieties

From the result shown, in Figure 50 for the dry season of planting it can be seen that plant height varied across the four different varieties indicating a significant difference in growth. However, there was no difference between the plant height of Sida variety and Eber variety as compared to the plant height of hybrid variety. The highest plant height was  $\pm 77.8$  cm in the hybrid variety which was significantly higher than that of other plants.

The result of the rainy season is shown in Figure 51. It can also be seen that there is no difference between the plant heights of Eber and Sida as compared to the plant height of the hybrid variety. The highest plant height was  $\pm 93.1$  cm in the hybrid



variety. There was no significant variation in plant height between the Sida and Eber varieties throughout the two planting seasons (dry and rainy).

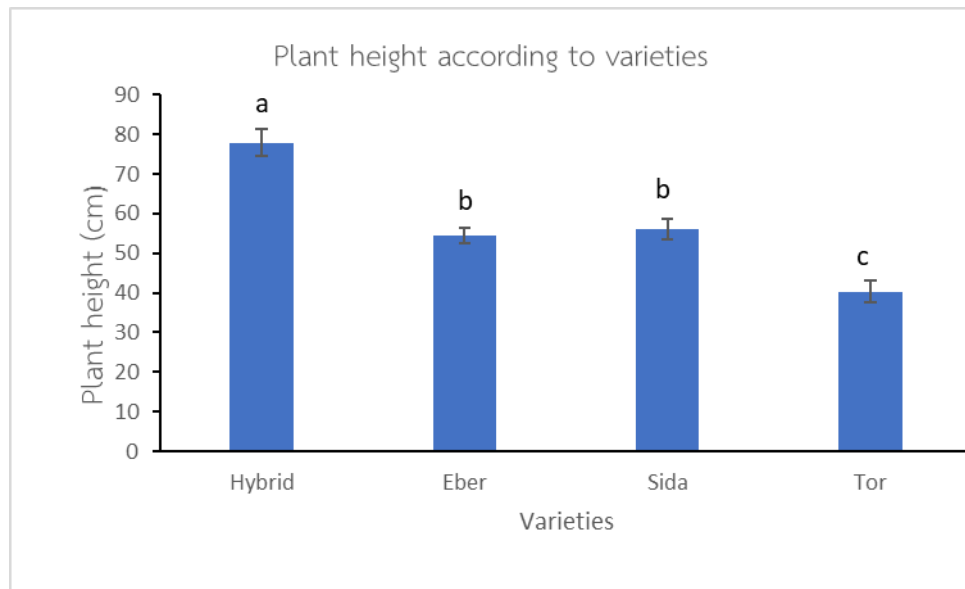
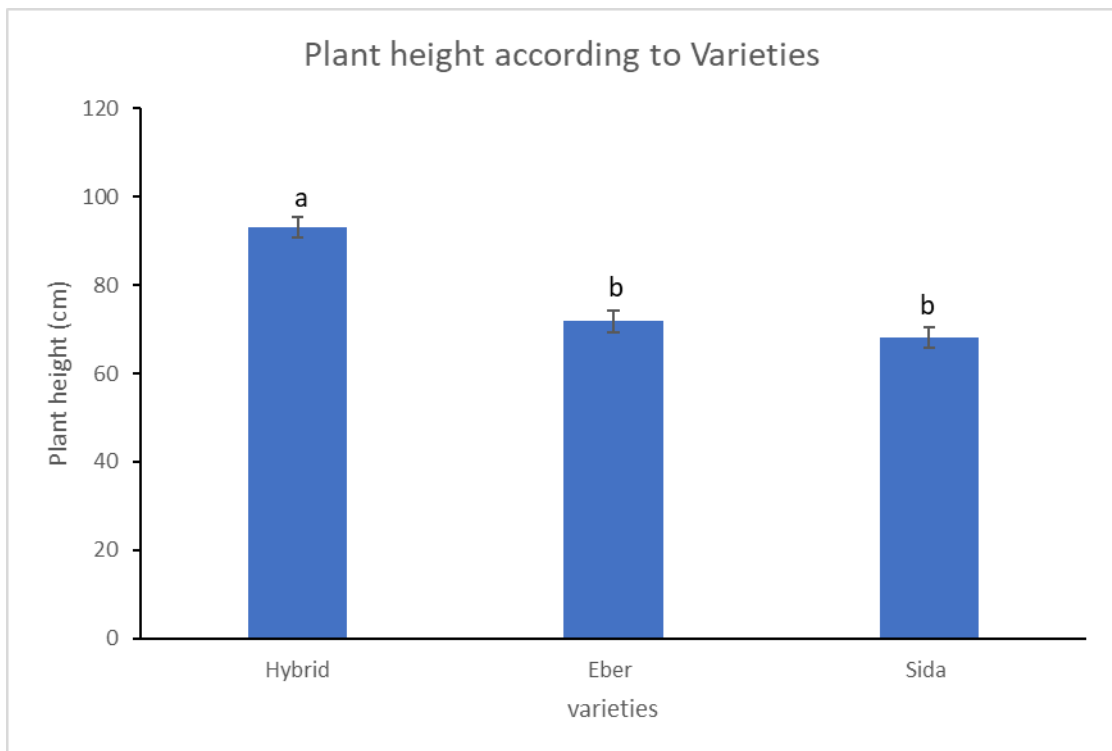


Figure 50 Plant height according to varieties in the dry season.

a, b, c= indicates significant difference at  $P < 0.05$



**Figure 51** Plant height according to varieties in the rainy season.

a, b= indicates a significant difference at  $P < 0.05$

#### 4.7 Plant growth during the dry season and rainy season

Figures 52 and 53, show a line graph of the different varieties used in the study. The graph shows an increase in slope signifying an increase in plant height; however, on the 13<sup>th</sup> of May, 2022, there was a decline in slope, indicating that the Eber variety and Sida variety had reached their full height. The same trend was also observed on the 23<sup>rd</sup> of July 2022, during the rainy season. When all varieties were compared, the rapid growth of Eber and Sida stopped at a certain stage, whereas hybrid grew continuously. This is because Eber and Sida are determinate varieties, and once plants reach their full height, they focus all of their nutrients on fruit production.

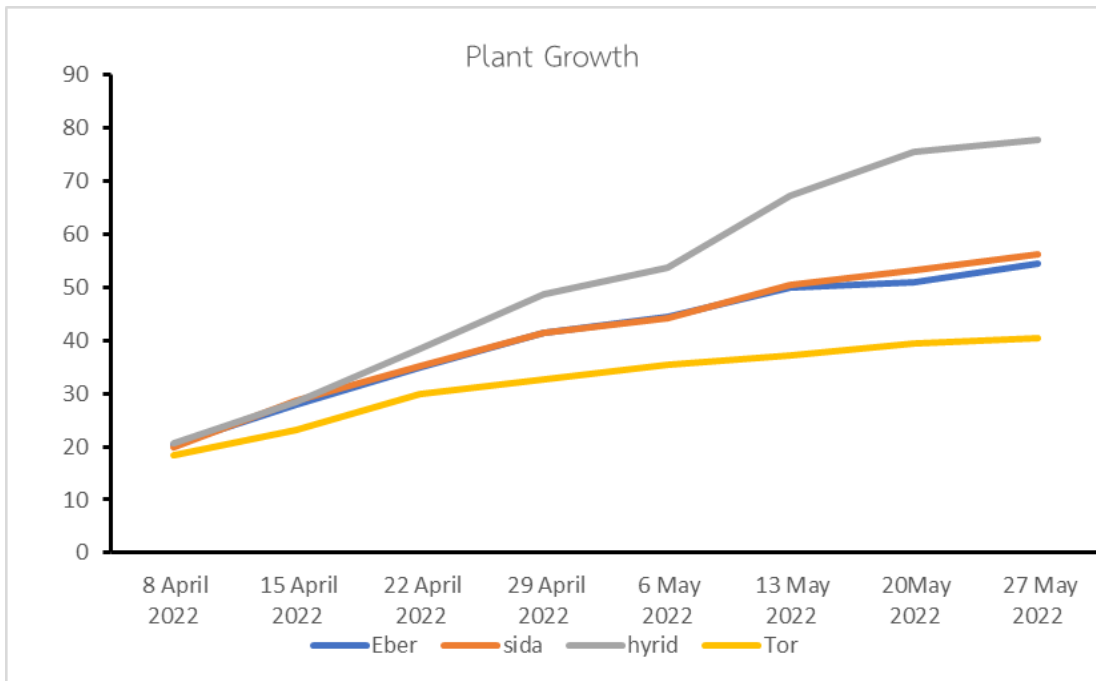


Figure 52 Plant growth in the dry season.

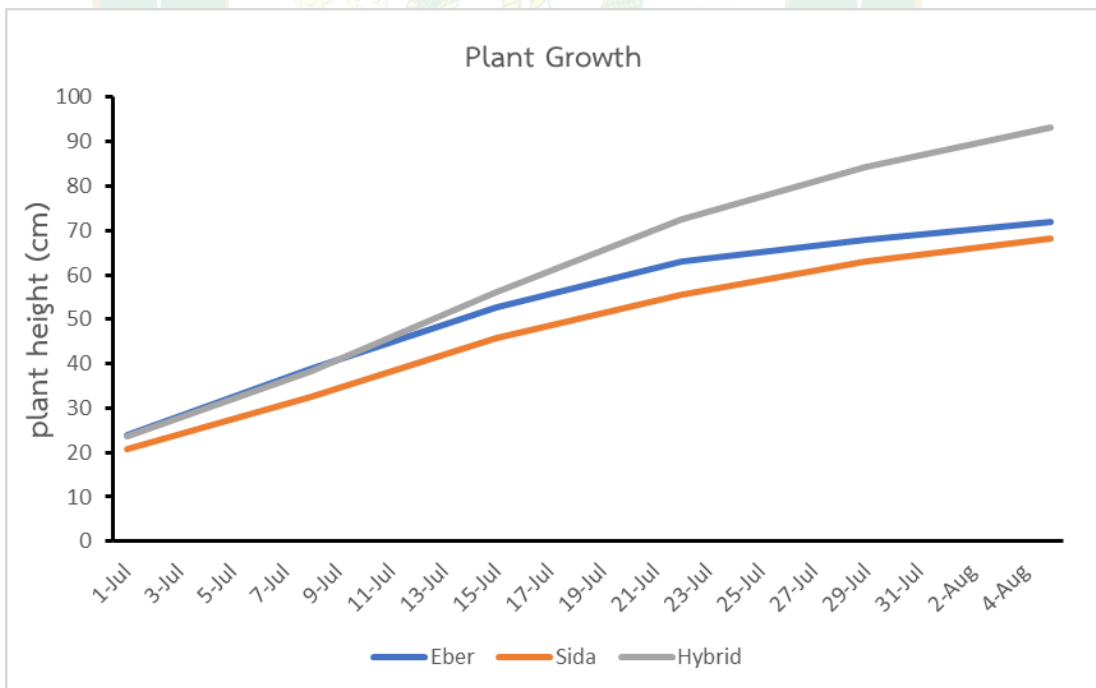
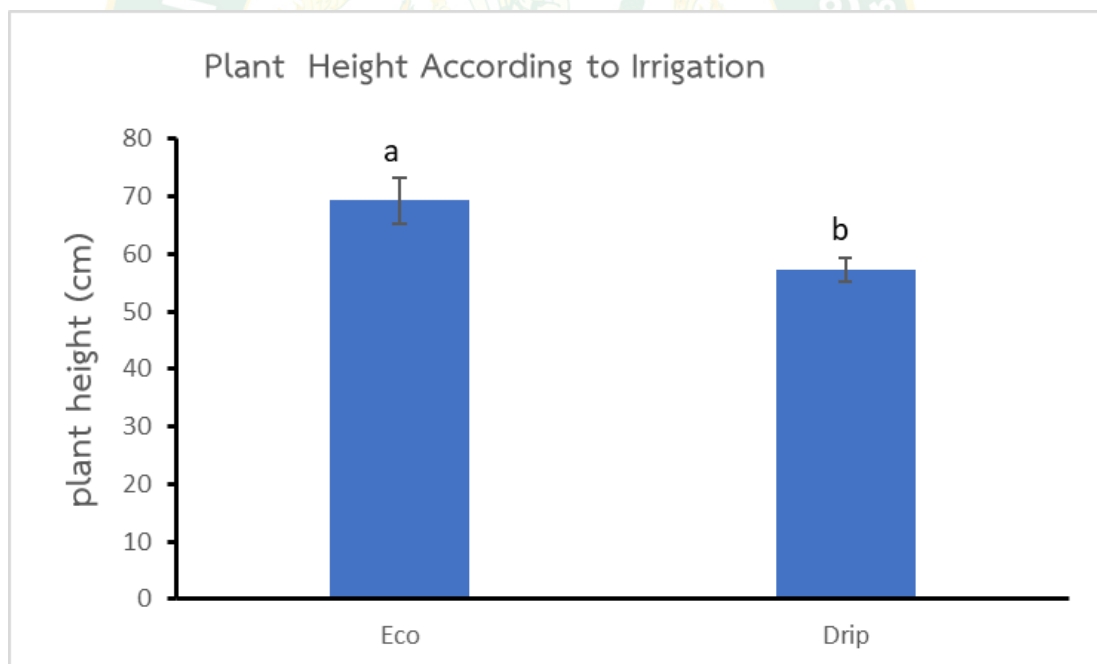


Figure 53 Plant growth in the rainy season.

#### 4.8 Plant Height According to the Irrigation system

There was no significant influence of the irrigation methods on plant height; however, the experiment revealed that less irrigation water resulted in increased plant height in both planting seasons. The results of plant height during the two planting seasons, as shown in figures 54 and 55 below, clearly reveal a difference between the use of drip irrigation and eco tubes during the dry and rainy seasons.

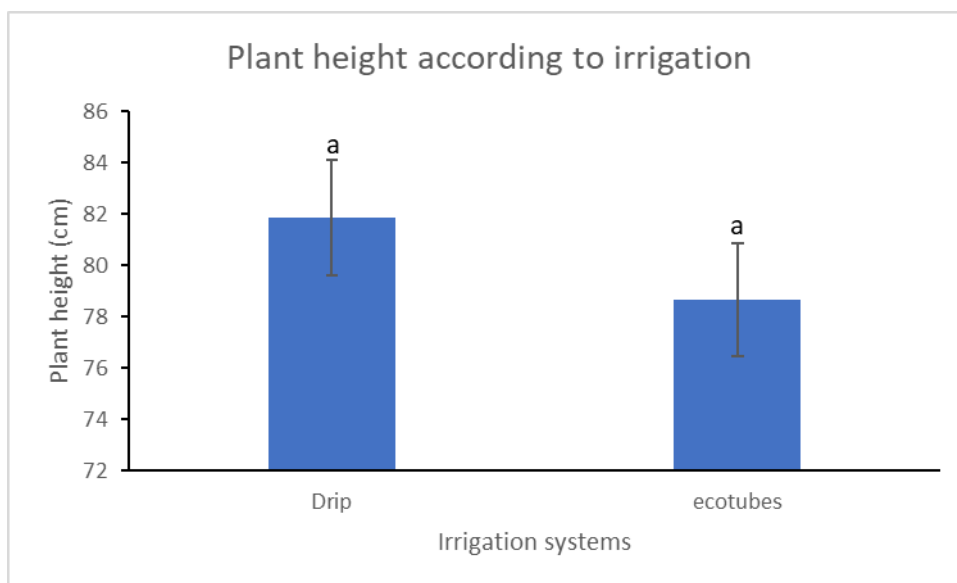
The eco tube irrigation performed better in terms of plant height by producing an average plant height of  $\pm 69.3$  cm as compared to drip irrigation which produced  $\pm 57.3$  cm during the dry seasons. This agrees with the findings of (Kunze et al., 2021), who stated in their experiment that plant height was higher in the use of eco tube irrigation compared to drip irrigation. In the rainy season, drip irrigation produced an average plant height of  $\pm 81.9$  cm as compared to the eco tube with  $\pm 78.66$  cm.



**Figure 54** Plant height according to irrigation for the dry season

a, b= indicates a significant difference at  $P < 0.05$ .

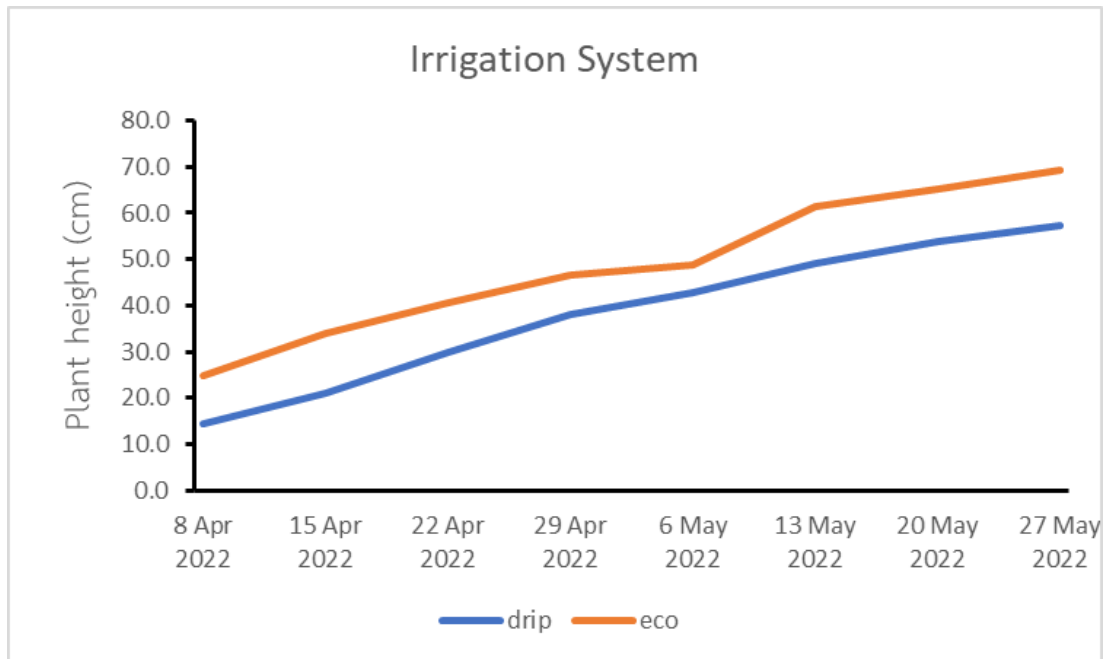




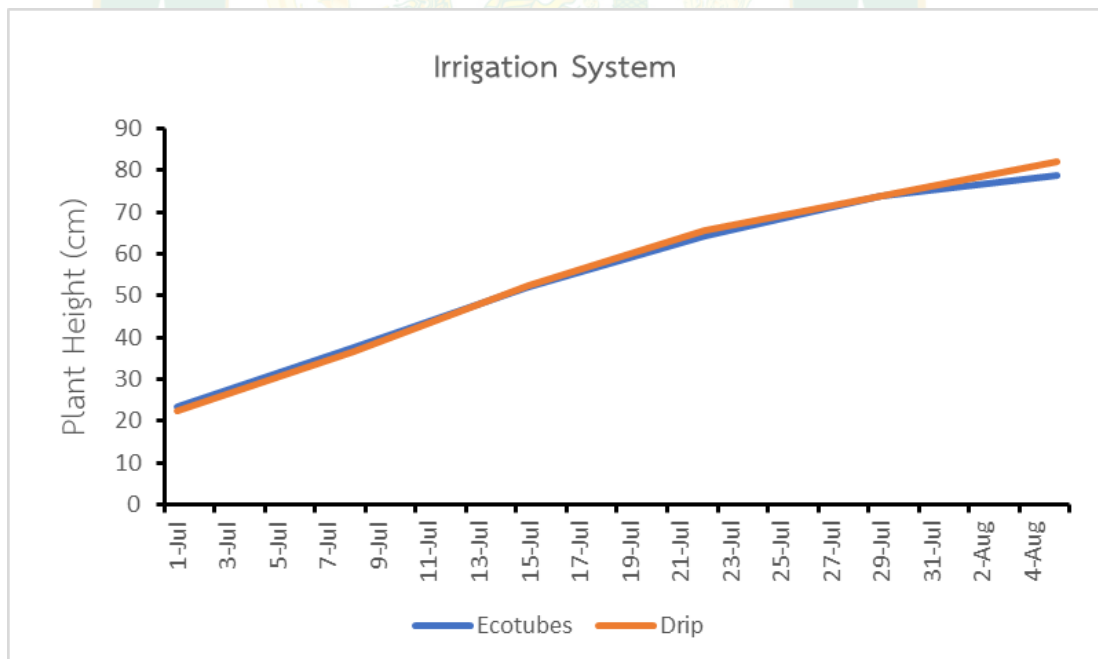
**Figure 55** plant height according to irrigation for the rainy season.  
a, a = indicates significant difference at  $P < 0.05$ .

#### 4.9 Plant response to Irrigation

Figures 56 and 57 represent line graphs of the two irrigation systems. According to figure 56, the plant height in the drip irrigation increased significantly in the early and mid-stages of growth and was visible, but there was only a slight increase in plant height at the final stage of growth. Plant height increased throughout the early stages of growth with the eco tube irrigation, but there was no obvious growth during the mid-stage, and there was a slight increase in plant height at the final stage. Figure 57 demonstrates that for both irrigation systems, plant height increased rapidly from the early stage to the mid-stage, with just a slight increase at the final stage of growth.



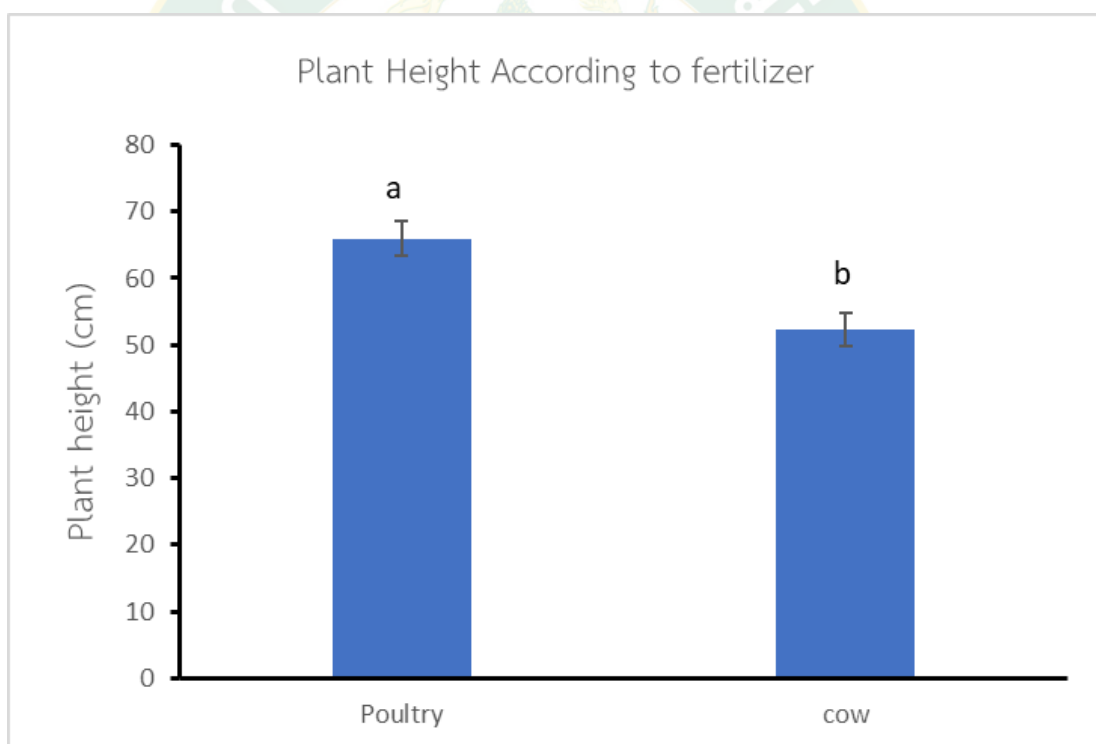
**Figure 56** The response of plant height to irrigation in the dry season.



**Figure 57** The response of plant height in the rainy season.

#### 4.10 Plant Height According to Fertilizer

The result in figure 58, shows a variation in plant height due to the influence of different starter fertilizers used (cow starter fertilizer and poultry starter fertilizer). It can be seen, that there was a significant difference between the use of poultry starter fertilizer and cow starter fertilizer. Comparing the two fertilizers used, the average plant height was higher in poultry starter fertilizer at  $\pm 65.9$  cm and cow starter fertilizer at  $\pm 52.3$  cm. This agreed with the finding of (Ayeni et al., 2010) and (Direkvandi et al., 2008) who stated a significant increase in plant height as a result of the application of poultry fertilizer to tomato plants. This is attributed to the proper release of N.P.K nutrients to the soil by the poultry starter.



**Figure 58** Plant height according to fertilizer  
a, b= indicates a significant difference at  $P < 0.05$

## CHAPTER 5

### CONCLUSION AND RECOMMENDATION

The research work was carried out to ascertain the response of different varieties of tomatoes to irrigation methods (drip and eco tube irrigation) and fertilizer supply (poultry starter fertilizer and cow starter fertilizer). A proper method of irrigation is essential to the production of crops, especially in a place like Thailand where water is scarce for irrigation during the dry season.

The first hypothesis of this research, states that there is no significant difference between crop performance in the use of drip irrigation and eco tube irrigation. However, the study showed a significant difference between crop performance in drip irrigation and eco tube irrigation in terms of plant height and biomass. It was observed during the dry season, the use of eco tube irrigation led to higher plant height compared to drip irrigation. This difference can be attributed to the subsurface installation of eco tubes, which enabled direct water supply to the plant roots and minimized evaporation. Although water was also supplied to the root of the plant in drip irrigation, evaporation could not be completely avoided. As demonstrated from the results, drip irrigation considerably consumed more irrigation water throughout both planting seasons, which resulted in higher overall biomass when compared to eco tube irrigation. Biomass was observed to be influenced by this increased irrigation water. During the dry season, no significant difference was observed between the two irrigation methods (drip and eco tube) in terms of yield. However, in the rainy season, a significant difference was observed between the two irrigation methods. The yield in the rainy season was significantly higher with the use of drip irrigation compared to eco tube irrigation. This is attributed to the negative impact of the rainfall on eco tube irrigation, which resulted in runoff and reduced water availability to the plant roots.

The second hypothesis states, that the water use efficiency in drip irrigation is significantly different from the water use efficiency in eco tube irrigation. The result from dry season showed that eco tube irrigation utilized lesser irrigation water than



drip irrigation, resulting in a higher water use efficiency. This can be explained by the supply of water at low pressure, allowing uniform water distribution to plant roots while reducing evaporation and deep percolation water losses and making this irrigation method water efficient. Drip irrigation was found to be more efficient in terms of water use than eco tube irrigation during the rainy season this was because, eco tube irrigation used more irrigation water, and there was a significant loss of water due to runoff as a result of heavy rainfall, which had an impact on field drainage as runoff was seen particularly on eco tube irrigation. This runoff can be explained by the subsurface installation of eco tubes, as well as the fact that they were not installed on dams. In the rainy season, the two irrigation systems (eco tube and drip irrigation) were used only under the polytunnels. Because there was no discernible difference between the two irrigation methods farmers have the option to select between eco tube and drip irrigation systems based on their available resources and preferences. However, farmers need to be aware that eco tube irrigation may have a higher water use efficiency compared to drip irrigation, which can result in cost savings in the long run. To ensure the optimal performance of eco tube irrigation, farmers should take into consideration the potential effect of heavy rainfall on the irrigation system. The subsurface installation of eco tubes and the absence of installation on dams may cause runoff, thereby negatively affecting field drainage. Thus, the choice of irrigation system should be based on a thorough assessment of factors such as cost-effectiveness, water use efficiency, and suitability for local conditions. Although any of the two irrigation methods can be used during the dry season it is not advisable to employ eco tube irrigation during the rainy season due to its inability to handle rainfall, as found in this study. However, further research is required to explore various installation and usage methods that could enhance eco tube irrigation's effectiveness in subsequent research.

The development of crops using the two starter fertilizers (cow and poultry), revealed that the use of poultry starter fertilizer produced higher fruit yield and plant growth

than the use of cow starter fertilizer. The yield was measured based on the number of fruits and the weight of the fruits, and it was discovered that more yield was produced from tomato plants when poultry starter fertilizer was used, due to the adequate amount of NPK (Nitrogen potassium and phosphorus) present in poultry starter fertilizer. Proper care must be taken when applying poultry starter fertilizer, as evidenced by the experiment, which revealed that replanting was required on some of the young plants due to the high Nitrogen concentration with poultry starter fertilizer, as plant damage would occur if not properly handled. As expected, the use of polytunnels had a huge impact on the yield obtained compared to no polytunnel used in the rainy season this is because, with the use of polytunnels, pests, and diseases were controlled to a minimum as well as other environmental factors such as temperature, and winds that could affect the yield were also controlled. Generally, comparing the different organic varieties used the best variety in terms of yield, plant growth, and above-ground biomass was Eber variety, its genetic composition allowed it to withstand harsh conditions and pests and diseases. The research showed that Eber variety had a high level of resistance to extreme weather conditions low rainfall, high temperature, and high humidity throughout the dry season, producing consistently good yields. To enhance crop yields under difficult environmental conditions, Eber variety can be used by farmers. The performance of the Tor and Sida varieties, which are the most popular organic varieties among organic farmers in Thailand, was poor. Farmers could instead go for Eber varieties, but Eber varieties are primarily produced at Maejo University and are not common among organic farmers in Thailand.

#### Recommendation

Based on the findings of this research:

1. Irrigation: organic farmers, have the choice to choose between eco tube and drip irrigation in the dry season. However, in the rainy season, drip irrigation is

recommended for farmers. But if eco tube irrigation must be used in the rainy season, the installation method should be changed from the subsurface method that was used in this research. A surface irrigation method with dams should be considered to prevent water runoff and improve field drainage. In addition, the use of polytunnels during the rainy season is important to avoid excess water for the plants. With the proper installation and appropriate use, both eco tube and drip irrigation can help to maintain a consistent supply of water to plants throughout the dry season. For the rainy season, drip irrigation and the use of polytunnels are recommended for optimal crop growth and yield.

2. Eber variety should be used by organic farmers in Thailand because of its high productivity and ability to withstand pests and diseases as demonstrated in the research. With Eber variety, the risk of crop failure is reduced especially during the dry season. Eber variety should also be made generally accessible to organic farmers in Thailand that way it could encourage farmers and make organic farming less difficult. This can be achieved by providing information on where to obtain the seeds, and ensuring that the seeds are available in local markets.
3. Vegetable farmers should use polytunnels in the rainy season as a way to improve yield by protecting plants from environmental factors. Polytunnels also provide a controlled environment for plants, minimizing the impact of high temperature and humidity levels. They can extend the growing season, encouraging earlier planting and later harvesting, and also protect crops from pests and diseases. In addition to these advantages, polytunnels can help to reduce water usage by preventing evaporation, making them a sustainable and environmentally-friendly choice for vegetable farming.
4. Poultry starter fertilizer should also be used by organic farmers as it helps to improve yield. The use of poultry starter fertilizer is a beneficial practice that

organic farmers should consider incorporating into their farming systems. Its ability to improve yield, promote sustainability, and reduce costs makes it a valuable resource for farmers looking to improve their overall farming practices.





## REFERENCES

- Acharya, B., Ingram, T. W., Oh, Y., Adhikari, T. B., Dean, R. A. & Louws, F. J. 2020. Opportunities and Challenges in Studies of Host-Pathogen Interactions and Management of *Verticillium dahliae* in Tomatoes. **Plants (Basel, Switzerland)**, 9(11).
- Aiyelaagbe, I., Abiola, I. & Sadiku, M. 2005. Growth response of Juvenile Passion Fruit (*Passiflora Edulis*, F. *Falvicarpa*) to organic and inorganic fertilizer in South Western Nigeria. **Nigerian Journal of Horticultural Science**, 10(1), 18-22.
- Akhoond-Ali, A. & Golabi, M. 2008. Subsurface porous pipe irrigation with vertical option as a suitable irrigation method for light soils. **Asian Journal of Scientific Research**, 1(3), 180-192.
- Allen, R. G., Pereira, L. S., Raes, D. & Smith, M. 1998. Crop evapotranspiration- Guidelines for computing crop water requirements-FAO Irrigation and drainage paper 56.
- Amosson, S., New, L., Almas, L., Bretz, F. & Marek, T. 2002. Economics of Irrigation Systems.
- Ashraf, Q. & Galor, O. 2011. Dynamics and Stagnation in the Malthusian Epoch. **American Economic Review**, 101(5), 2003-2041.
- Assefa, S. & Tadesse, S. 2019. The principal role of organic fertilizer on soil properties and agricultural productivity-a review. **Agri Res and Tech: Open Access J**, 22(2), 556192.
- Ayeni, L., Omole, T., Adeleye, E. & Ojeniyi, S. 2010. Integrated application of poultry manure and NPK fertilizer on performance of tomato in derived savannah transition zone of southwest Nigeria. **Science and Nature**, 8(2), 50-54.
- Ayi, Q., Zeng, B., Liu, J., Li, S., van Bodegom, P. M. & Cornelissen, J. H. C. 2016. Oxygen absorption by adventitious roots promotes the survival of completely submerged terrestrial plants. **Annals of Botany**, 118(4), 675-683.

- Balaj, N., Zejnollahi, E. D. & Haxhinasto, L. 2017. Raw material of plant origin: cultivation tomato vegetable plant (*Solanum lycopersicum*) in Kosovo.
- Barman, U., Choudhury, R. D., Saud, A., Dey, S., Pratim, M. & Gunjan, B. 2018. Estimation of chlorophyll using image processing. **Int J Recent Sci Res**, 9(3), 24850-24853.
- Baysal, F., McSpadden-Gardener, B., Cardina, J., Kleinhenz, M. & Miller, S. 2009. Effect of transition strategy and production system on disease development in organic tomatoes. **Acta Hort.**, 808(113-116).
- Beecher, G. R. 1998. Nutrient Content of Tomatoes and Tomato Products. **Proceedings of the Society for Experimental Biology and Medicine**, 218(2), 98-100.
- Belay, A., Claassens, A. S., Wehner, F. C. & de Beer, J. M. 2001. Influence of residual manure on selected nutrient elements and microbial composition of soil under long-term crop rotation. **South African Journal of Plant and Soil**, 18(1), 1-6.
- Bergougnoux, V. 2014. The history of tomato: From domestication to biopharming. **Biotechnology Advances**, 32(1), 170-189.
- Bisbis, M. B., Gruda, N. & Blanke, M. 2018. Potential impacts of climate change on vegetable production and product quality – A review. **Journal of Cleaner Production**, 170(1602-1620).
- Biswas, S., Akanda, A., Rahman, M. & Hossain, M. 2016. Effect of drip irrigation and mulching on yield, water-use efficiency and economics of tomato. **Plant, Soil and Environment**, 61(3), 97-102.
- Cetin, O. & Uygan, D. 2008. The effect of drip line spacing, irrigation regimes and planting geometries of tomato on yield, irrigation water use efficiency and net return. **Agricultural Water Management**, 95(8), 949-958.
- Chen, S. & Gong, B. 2021. Response and adaptation of agriculture to climate change: Evidence from China. **Journal of Development Economics**, 148(102557).
- Conner, D. S., Montri, A. D., Montri, D. N. & Hamm, M. W. 2010. Consumer demand for local produce at extended season farmers' markets: guiding farmer marketing strategies. **Renewable Agriculture and Food Systems**, 24(4), 251-259.

- Diacono, M. & Montemurro, F. (2011). Long-Term Effects of Organic Amendments on Soil Fertility. In E. Lichtfouse, M. Hamelin, M. Navarrete & P. Debaeke (Eds.), **Sustainable Agriculture Volume 2** (pp. 761-786). Dordrecht: Springer Netherlands.
- Direkvandj, S. N., Ansari, N. A. & Dehcordie, F. S. 2008. Effect of different levels of nitrogen fertilizer with two types of bio-fertilizers on growth and yield of two cultivars of tomato (*Lycopersicon esculentum* Mill). **Asian Journal of Plant Sciences**, 7(8), 757.
- Dorais, M., Ehret, D. L. & Papadopoulos, A. P. 2008. Tomato (*Solanum lycopersicum*) health components: from the seed to the consumer. **Phytochemistry Reviews**, 7(2), 231-250.
- Easter, K. W. & Welsch, D. E. (2019). Implementing irrigation projects: operational and institutional problems. In **Irrigation Investment, Technology, and Management Strategies for Development** (pp. 33-56): Routledge.
- Eaton, D., Wiersinga, R., Bastakoti, R. C., Selvaraj, K., Zaden, E., Seeds, N. V. & Seeds, S. V. 2008. Impact of improved vegetable farming technology on farmers' livelihoods in tropical Asia. **LEI, Wageningen University and Research Center, Wageningen**.
- Ekelund, L. & Tjarnemo, H. 2004. **CONSUMER PREFERENCES FOR ORGANIC VEGETABLES - THE CASE OF SWEDEN**. International Society for Horticultural Science (ISHS), Leuven, Belgium.
- Ellis, W., Panyakul, V., Vildoza, D. & Kasterine, A. 2006. Strengthening the export capacity of Thailand's organic agriculture. **Geneva: International Trade Centre**.
- Fan, S., Jitsuchon, S. & Methakunnavut, N. (2004). **The importance of public investment for reducing rural poverty in middle-income countries: The case of Thailand**. Document Number)
- Faucon, M.-P., Houben, D. & Lambers, H. 2017. Plant Functional Traits: Soil and Ecosystem Services. **Trends in Plant Science**, 22(5), 385-394.

- Gatahi, D. M. 2020. Challenges and Opportunities in Tomato Production Chain and Sustainable Standards. **International Journal of Horticultural Science and Technology**, 7(3), 235-262.
- Geisenberg, C. & Stewart, K. (1986). Field crop management. In J. G. Atherton and J. Rudich (Eds.), **The Tomato Crop: A scientific basis for improvement** (pp. 511-557). Dordrecht: Springer Netherlands.
- Ginting, D., Kessavalou, A., Eghball, B. & Doran, J. W. 2003. Greenhouse Gas Emissions and Soil Indicators Four Years after Manure and Compost Applications. **Journal of Environmental Quality**, 32(1), 23-32.
- Gutierrez, E. E. V. 2018. An overview of recent studies of tomato (*Solanum Lycopersicum* spp) from a social, biochemical and genetic perspective on quality parameters. **Basic Microbiology**, 50(211-217).
- Ha, T. M. 2015. Agronomic Requirements of Tomatoes and Production Methods in the Red River Delta of Vietnam. **Journal of Tropical Crop Science**, Vol 2 No 1 (2015): *Journal of Tropical Crop Science*, 33-38.
- Haque, M. M., Datta, J., Ahmed, T., Ehsanullah, M., Karim, M. N., Akter, M. S., Iqbal, M. A., Baazeem, A., Hadifa, A., Ahmed, S. & El Sabagh, A. 2021. Organic Amendments Boost Soil Fertility and Rice Productivity and Reduce Methane Emissions from Paddy Fields under Sub-Tropical Conditions. **Sustainability**, 13(6). Available
- Hargreaves, G. H. & Samani, Z. A. 1982. Estimating potential evapotranspiration. **Journal of the irrigation and Drainage Division**, 108(3), 225-230.
- Hartz, T., Miyao, G., Mickler, J., Lestrangle, M., Stoddard, S., Nuñez, J. & Aegerter, B. 2008. Processing tomato production in California.
- Hazman, M. Y., El-Sayed, M. E. A., Kabil, F. F., Helmy, N. A., Almas, L., McFarland, M., Shams El Din, A. & Burian, S. 2022. Effect of Biochar Application to Fertile Soil on Tomato Crop Production under Saline Irrigation Regime. **Agronomy**, 12(7). Available
- Huuml, snuuml, U., nluuml, Halime, O., Uuml, z., nluuml, Yaar, K., Huuml & seyin, P. 2011. Influence of organic and conventional production systems on the quality of tomatoes during storage. **African Journal of Agricultural Research**, 6(3), 538-544.



- Ibeawuchi, I., Obiefuna, J., Tom, C., Ihejirika, G. & Omobvude, S. 2015. Indigenous and current practices in organic agriculture in Nigeria: a review. **Agric For Fish**, 4(6), 257-262.
- Ilić, S. Z., Kapoulas, N. & Šunić, L. (2014). Tomato Fruit Quality from Organic and Conventional Production. In P. Vytautas (Ed.), **Organic Agriculture Towards Sustainability** (pp. Ch. 7). Rijeka: IntechOpen.
- Jahroh, S. 2010. **ORGANIC FARMING DEVELOPMENT IN INDONESIA: LESSONS LEARNED FROM ORGANIC FARMING IN WEST JAVA AND NORTH SUMATRA**. 2010-06-28. Cirad-Inra-SupAgro.
- Joya, K., Ramli, N. N., Shamsudin, M. N. & Kamarulzaman, N. H. 2022. Consumers' willingness to pay for food safety attributes of tomato. **British Food Journal**, 124(3), 701-717.
- Kano-Nakata, M., Inukai, Y., Wade, L. J., Siopongco, J. D. L. C. & Yamauchi, A. 2011. Root Development, Water Uptake, and Shoot Dry Matter Production under Water Deficit Conditions in Two CSSLs of Rice: Functional Roles of Root Plasticity. **Plant Production Science**, 14(4), 307-317.
- Karungi, J., Kyamanywa, S., Adipala, E. & Erbaugh, M. 2011. **Pesticide utilisation, regulation and future prospects in small scale horticultural crop production systems in a developing country**. chapter.
- Katung, M., Hassbini, I. & Olarewaju, J. 2005. Yield and storability of onion (*Allium cepa* L.) as influenced by organic and inorganic fertilizers in the Sudan Savanna region of Nigeria. **Nigerian Journal of Horticultural Science**, 10(1), 82-86.
- Khosro, M., Gholamreza, H., Shiva, K. & Yousef, S. 2011. Soil management, microorganisms and organic matter interactions: A review. **African Journal of Biotechnology**, 10(86), 19840-19849.
- Kirby, M., Ahmad, M.-u.-D., Mainuddin, M., Khaliq, T. & Cheema, M. J. M. 2017. Agricultural production, water use and food availability in Pakistan: Historical trends, and projections to 2050. **Agricultural Water Management**, 179(34-46).
- Koevoets, I. T., Venema, J. H., Elzenga, J. T. M. & Testerink, C. 2016. Roots Withstanding their Environment: Exploiting Root System Architecture Responses to Abiotic Stress to Improve Crop Tolerance. **Frontiers in Plant Science**, 7(

- Kortbech-Olesen, R. 2000. **World Trends in Consumption and Trade of Exotic Food and Beverages with Emphasis on Organic Products.**
- Kshirsagar, K. 2008. ENVIRONMENTAL DEGRADATION AND ITS CORRECTIVES IN AGRICULTURE SECTOR-Organic Sugarcane Farming for Enhancing Farmers' Income and Reducing the Degradation of Land and Water Resources in Maharashtra. **Indian Journal of Agricultural Economics**, 63(3), 396.
- Kunze, A., Spreer, W., Dangtungee, R., Boonrahong, C., Sanguangpong, U. & Max, J. 2021. **Comparison of an innovative porous pipe irrigation system to drip irrigation under controlled conditions.**
- Lamont, W. J. 2009. Overview of the Use of High Tunnels Worldwide. **HortTechnology hortte**, 19(1), 25-29.
- Luthria, D. L., Mukhopadhyay, S. & Krizek, D. T. 2006. Content of total phenolics and phenolic acids in tomato (*Lycopersicon esculentum* Mill.) fruits as influenced by cultivar and solar UV radiation. **Journal of Food Composition and Analysis**, 19(8), 771-777.
- Marouelli, W. A., de Medeiros, M. A., de Souza, R. F. & Resende, F. V. 2011. Produção de tomateiro orgânico irrigado por aspersão e gotejamento, em cultivo solteiro e consorciado com coentro. **Horticultura Brasileira**, 29(429-434).
- Martí, R., Roselló, S. & Cebolla-Cornejo, J. 2016. Tomato as a Source of Carotenoids and Polyphenols Targeted to Cancer Prevention. **Cancers**, 8(6), 58.
- Mbah, C. 2006. Influence of organic waste on plant growth parameters and nutrient uptake by maize (*Zea may* L). **Nigerian Journal of Soil Science**, 16(104-108).
- Mondal, S., Haitook, T. & Simaraks, S. 2014. Farmers' knowledge, attitude and practice toward organic vegetables cultivation in Northeast Thailand. **Kasetsart Journal of Social Sciences**, 35(1), 158-166.
- Monte, J. A., de Carvalho, D. F., Medici, L. O., da Silva, L. D. B. & Pimentel, C. 2013. Growth analysis and yield of tomato crop under different irrigation depths/Análise de crescimento e produtividade da cultura do tomateiro sob diferentes lâminas de irrigação. **Revista Brasileira de Engenharia Agrícola e Ambiental**, 17(926+).

- Monte, J. A., Pacheco, A. d. S., de Carvalho, D. F. & Pimentel, C. 2009. "Influence of irrigation shift on growth and production of tomato in summer in Seropédica." **Horticultura Brasileira**, 27(222-227).
- Morgan, K. & Murdoch, J. 2000. Organic vs. conventional agriculture: knowledge, power and innovation in the food chain<sup>11</sup>. **Geoforum**, 31(2), 159-173.
- Nathan, M. V., Stecker, J. A. & Sun, U. 2012. Soil testing in Missouri: A guide for conducting soil tests in Missouri (2012).
- Nicola, S., Tibaldi, G., Fontana, E., Crops, A.-V. & Plants, A. 2009. Tomato production systems and their application to the tropics. **Acta horticulturae**, 821(821), 27-34.
- Niggli, U. 2007. **Holistic approaches in organic farming research and development: a general overview**. FAO and FiBL Rome, Italia.
- Orzolek, M. D., Lamont, W. J. & White, L. 2004. **PROMISING HORTICULTURAL CROPS FOR PRODUCTION IN HIGH TUNNELS IN THE MID-ATLANTIC AREA OF THE UNITED STATES**. International Society for Horticultural Science (ISHS), Leuven, Belgium.
- Ozbahce, A. & Tari, A. F. 2010. Effects of different emitter space and water stress on yield and quality of processing tomato under semi-arid climate conditions. **Agricultural Water Management**, 97(9), 1405-1410.
- Pattanapant, A. & Shivakoti, G. P. 2013. Opportunities and constraints of organic agriculture in Chiang Mai Province, Thailand. **Asia-Pacific Development Journal**, 16(1), 115-147.
- Pem, D. & Jeewon, R. 2015. Fruit and Vegetable Intake: Benefits and Progress of Nutrition Education Interventions- Narrative Review Article. **Iran J Public Health**, 44(10), 1309-1321.
- Pires, R., Furlani, P., Sakai, E., Lourenção, A., Silva, E., Neto, A. & Melo, A. 2009. Tomato development and yield under different irrigation frequencies in greenhouse. **Horticultura Brasileira**, 27(228-234).
- Pltonykova, H., Koepfel, S., Bernardini, F., Tiefenauer-Linardon, S. & de Strasser, L. (2020). **The United Nations World Water Development Report 2020: Water and Climate Change**: UNESCO for UN-Water.

- Prabhakar, M. & Rank, H. 2022. Field evaluation of effectiveness of subsurface porous pipe irrigation system on sweet corn (*Zea mays L. saccharata*) crop yield, water and fertilizer use efficiency. **Journal of Tropical Agriculture**, 59(2).
- Preece, C. & Peñuelas, J. 2016. Rhizodeposition under drought and consequences for soil communities and ecosystem resilience. **Plant and Soil**, 409(1), 1-17.
- Quinet, M., Angosto, T., Yuste-Lisbona, F. J., Blanchard-Gros, R., Bigot, S., Martinez, J.-P. & Lutts, S. 2019. Tomato fruit development and metabolism. **Frontiers in plant science**, 10(1554).
- Rogers, M. A. & Wszelaki, A. L. 2012. Influence of High Tunnel Production and Planting Date on Yield, Growth, and Early Blight Development on Organically Grown Heirloom and Hybrid Tomato. **HortTechnology hortte**, 22(4), 452-462.
- Romero-Aranda, R., Soria, T. & Cuartero, J. 2001. Tomato plant-water uptake and plant-water relationships under saline growth conditions. **Plant Science**, 160(2), 265-272.
- Rosset, P., Rice, R. & Watts, M. 2021. Thailand and the World Tomato: globalization, new agricultural countries (NACs) and the agrarian question. **The International Journal of Sociology of Agriculture and Food**, 8(71-94).
- Rugchat, J. 2021. From Highland Tomatoes to Lowland Markets: the Diversification of Power Relations in Thai Tomato Trading. **Available at SSRN 3957359**.
- Shao, G., Cheng, X., Liu, N. & Zhang, Z. 2016. Effect of drought pretreatment before anthesis and post-anthesis waterlogging on water relation, photosynthesis, and growth of tomatoes. **Archives of Agronomy and Soil Science**, 62(7), 935-946.
- Sharma, H. S. S., Fleming, C., Selby, C., Rao, J. R. & Martin, T. 2014. Plant biostimulants: a review on the processing of macroalgae and use of extracts for crop management to reduce abiotic and biotic stresses. **Journal of Applied Phycology**, 26(1), 465-490.
- Siyal, A. A. & Skaggs, T. H. 2009. Measured and simulated soil wetting patterns under porous clay pipe sub-surface irrigation. **Agricultural Water Management**, 96(6), 893-904.



- Suwannarach, N., Kumla, J., Nitiyon, S., Limtong, S. & Lumyong, S. 2016. First report of sour rot on tomato caused by *Galactomyces reessii* in Thailand. **Journal of General Plant Pathology**, 82(4), 228-231.
- Tanimu, J., Iwuafor, E., Odunze, A. & Tian, G. 2007. Effect of incorporation of leguminous cover crops on yield and yield components of maize. **World Journal of Agricultural Sciences**, 3(2), 243-249.
- Thapa, G. B. & Rattanasuteerakul, K. 2011. Adoption and extent of organic vegetable farming in Mahasarakham province, Thailand. **Applied Geography**, 31(1), 201-209.
- Thepent, V. & Chamsing, A. 2009. Agricultural mechanization development in Thailand. **The Fifth Session of the Technical Committee of APCAEM, Los Banos, Philippines, October**, 14-16.
- Thirtle, C., Lin, L. & Piesse, J. 2003. The Impact of Research-Led Agricultural Productivity Growth on Poverty Reduction in Africa, Asia and Latin America. **World Development**, 31(12), 1959-1975.
- Tonfack, L. B., Bernadac, A., Youmbi, E., Mbouapouognigni, V. P., Ngueguim, M. & Akoa, A. 2009. Impact of organic and inorganic fertilizers on tomato vigor, yield and fruit composition under tropical andosol soil conditions. **Fruits**, 64(3), 167-177.
- Tosun, N., Karabay, N. Ü. & Sayim, F. 2001. Pesticide usage and their potential adverse impacts on living organisms. **Anadolu J AARI**, 11(1), 113-125.
- Ugonna, C., Jolaoso, M. & Onwualu, A. 2015. Tomato value chain in Nigeria: Issues, challenges and strategies. **J. Sci. Res. Rep**, 7(7), 501-515.
- Usman, M. 2015. Cow dung, goat and poultry manure and their effects on the average yields and growth parameters of tomato crop. **Journal of biology, agriculture and healthcare**, 5(5), 7-10.
- Verma, B. C., Pramanik, P. & Bhaduri, D. (2020). Organic Fertilizers for Sustainable Soil and Environmental Management. In R. S. Meena (Ed.), **Nutrient Dynamics for Sustainable Crop Production** (pp. 289-313). Singapore: Springer Singapore.
- Victoria, N., van der Valk, O. & Elings, A. 2011. Mexican protected horticulture: Production and market of Mexican protected horticulture described and analysed.

- Viuda-Martos, M., Sanchez-Zapata, E., Sayas-Barberá, E., Sendra, E., Pérez-Álvarez, J. A. & Fernández-López, J. 2014. Tomato and Tomato Byproducts. Human Health Benefits of Lycopene and Its Application to Meat Products: A Review. **Critical Reviews in Food Science and Nutrition**, 54(8), 1032-1049.
- Wang, X. & Xing, Y. 2017. Evaluation of the effects of irrigation and fertilization on tomato fruit yield and quality: a principal component analysis. **Scientific Reports**, 7(1), 350.
- White, B. 2012. Agriculture and the Generation Problem: Rural Youth, Employment and the Future of Farming. **IDS Bulletin**, 43(6), 9-19.
- Willer, H. & Sahota, A. 2020. The world of organic agriculture, statistics and emerging trends 2020 at BIOFACH 2020.
- Worley, R. E. 1976. Response of Tomato to pH of a Coastal Plain Soil1. **Journal of the American Society for Horticultural Science**, 101(4), 460-462.
- Xiukang, W. & Yingying, X. 2016. Evaluation of the Effect of Irrigation and Fertilization by Drip Fertigation on Tomato Yield and Water Use Efficiency in Greenhouse. **International Journal of Agronomy**, 2016(3961903).
- Zepeda, L. & Deal, D. 2009. Organic and local food consumer behaviour: Alphabet Theory. **International Journal of Consumer Studies**, 33(6), 697-705.
- Zhang, H., Xiong, Y., Huang, G., Xu, X. & Huang, Q. 2017. Effects of water stress on processing tomatoes yield, quality and water use efficiency with plastic mulched drip irrigation in sandy soil of the Hetao Irrigation District. **Agricultural Water Management**, 179(205-214).
- Zhou, R., Kong, L., Wu, Z., Rosenqvist, E., Wang, Y., Zhao, L., Zhao, T. & Ottosen, C.-O. 2019. Physiological response of tomatoes at drought, heat and their combination followed by recovery. **Physiologia Plantarum**, 165(2), 144-154.
- Zotarelli, L., Dukes, M. D., Scholberg, J. M. S., Muñoz-Carpena, R. & Icerman, J. 2009. Tomato nitrogen accumulation and fertilizer use efficiency on a sandy soil, as affected by nitrogen rate and irrigation scheduling. **Agricultural Water Management**, 96(8), 1247-1258.







## CURRICULUM VITAE

**NAME** Ajadi Adeife Victoria

**DATE OF BIRTH** 16 July 1994

**EDUCATION** Bachelor of Agriculture - University of Ilorin Nigeria (2014-2017)

**WORK EXPERIENCE** Research Assistant - International College Maejo University (2020-2022)

